

# **PETOL™ HYDRA-TORK™**

## **U4174**

### **Operating Manual**

**GEARENCH™**  
**P.O. Box 192**  
**4450 South Highway 6**  
**Clifton, Texas 76634**  
**Phone: (254) 675-8651**  
**Fax: (254) 675-6100**

© 2013 by GEARENCH. All rights reserved

Form: U4174 revision 02/12/13

## Table of Contents

<b>PETOL™ U4174 HYDRA-TORK™ DESCRIPTION.....</b>	<b>3</b>
<b>TORQUE RATING .....</b>	<b>3</b>
<b>WARRANTY.....</b>	<b>4</b>
<b>SAFE PRACTICES AND PROCEDURES .....</b>	<b>6</b>
RESPONSIBILITY .....	6
REPLACEMENT PARTS .....	6
SAFETY.....	6
SAFE PRACTICES.....	7
RESPONSIBILITY OF DISTRIBUTORS .....	7
<b>TONG AND VISE CHAIN INSPECTION.....</b>	<b>8</b>
OVERLOADING / SHOCK LOADS / SIDE LOADING .....	8
ENVIRONMENTAL CONDITIONS.....	8
NORMAL LIFE EXPECTANCY.....	9
LUBRICATION .....	9
PERIODIC INSPECTION LIST FOR PETOL SPECIAL CHAIN .....	10
<b>INSTALLATION.....</b>	<b>13</b>
LOCATION.....	13
SETUP .....	13
<b>OPERATION .....</b>	<b>13</b>
<b>TORQUE – PRESSURE CONVERSION CHART.....</b>	<b>14</b>
CHAIN SELECTION .....	15
LOADING .....	17
TONG ADJUSTMENT.....	17
BREAKING OUT .....	17
MAKING UP .....	17
<b>PARTS LIST .....</b>	<b>19</b>
FINAL ASSEMBLY .....	20
CYLINDER ASSEMBLY .....	21
BACKUP ASSEMBLY .....	22
TONG ASSEMBLY .....	23
VEE SADDLE ASSEMBLY .....	24
PETOL SPECIAL CHAIN PARTS LIST .....	25

## **PETOL™ U4174 HYDRA-TORK™ Description**

The U4174 PETOL™ HYDRA-TORK™ unit was designed for making up and breaking out downhole tools. It is rated for operation on 3-1/4" to 8-1/4" diameters with a maximum working load of 17,500 ft-lbs. The unit may be operated in any position (horizontal or inclined) and is totally portable.

The PETOL Drill Pipe Tongs are adjusted to the different diameters within their range by adjusting the chain screw nut for fine adjustment and by adding or removing sections of chain for the coarse adjustment.

The U4174 also offers the following features:

The tong cylinder and backup tong are mounted on independent tracks for adjusting and switching from make up to break out.

Two adjustable vee-saddles mounted on the hydra-tork base for support. The vee-saddles are also mounted on tracks for easy adjustment.

The unit can be operated with any commercially available hydraulic power unit capable of delivering 3000-psi pressure.

## **Torque Rating**

**The following working load limits should always be observed. Exceeding these limits could result in breaking the tong chain resulting in damage to equipment and possible injury to personnel.**

Diameter	Max. Torque
3" – 4-5/8"	16,900 ft-lbs
4-3/4" – 5-7/8"	17,100 ft-lbs
6" – 6-7/8"	17,300 ft-lbs
7" – 8-1/4"	17,500 ft-lbs

# **Warranty**

## **What Is Covered**

GEARENCH™ tools are expressly warranted to you, the purchaser, to be free of defects in material and workmanship.

## **How Long Coverage Lasts**

This express warranty lasts for the lifetime of the GEARENCH tool. Warranty coverage ends when the tool becomes unusable for reasons other than defects in workmanship or material.

## **How Can You Get Warranty Service**

To obtain the benefit of this warranty, contact a GEARENCH sales representative in Clifton, Texas.

GEARENCH · 4450 South Highway 6 · P.O. Box 192 · Clifton, TX 76634

## **What Will We Do To Correct Problems**

Warranted products will be repaired or replaced, at GEARENCH's option, and returned at no charge to you, the original purchaser; or, if after three attempts at repair or replacement during the warranty period, the product defect in material or workmanship persists, you can elect to receive a full refund of your original purchase price for the product.

## **What Is Not Covered**

Defects, failures or conditions that are due to normal wear and tear, abuse or misuse, are not covered by this limited warranty. In addition, this limited warranty is in lieu of all other warranties, express or implied, verbal or written. To the maximum extent allowed by law GEARENCH disclaims all implied warranties, including implied warranties of merchantability and/or fitness for a particular purpose. GEARENCH also specifically denies any liability for any incidental damages and/or consequential damages, including but not limited to property damage to property other than the product itself, loss of sales profits, down time, costs or any other damages measurable in money, whether or not included in the foregoing enumeration.

Please be advised that some states do not allow the exclusion or limitation of incidental or consequential damages, so this limitation or exclusion may not apply to you. This warranty gives you specific rights, and you may also have other rights, which vary from state to state, province to province, or country to country.

## **Are Personal Injuries Covered**

In the event you, someone working for you, or any other person sustain a personal injury as a result of using the GEARENCH tool, GEARENCH limits its potential liability for such a claim or injury to the fullest extent allowed by law, and disclaims and denies any liability for such personal injury.

Please be advised that some states do not allow the exclusion or limitation of liability for personal injuries, so the above limitation or exclusion may not apply to you, or the individual claiming injury.

## **No Other Express Warranty Applies**

This GEARENCH LIMITED WARRANTY is the sole and exclusive warranty, express or implied for GEARENCH products. No employee, agent, dealer or other person is authorized to alter, modify, expand or reduce the terms of this warranty or to make any other warranty on behalf of GEARENCH.

## **Law Applicable**

All matters related to the sale and/or use of the GEARENCH tool that is the subject of this limited warranty, along with the construction and enforcement of the terms of this limited warranty itself, shall be subject to the substantive and procedural laws of the state of Texas, not the conflicts of laws provisions of Texas, but rather the laws of Texas themselves.

**Forum Selection Clause**

Any dispute arising out of the sale and/or use of the GEARENCH tool that is the subject of this limited warranty shall be presented in the form of a claim or lawsuit to the offices of GEARENCH in Clifton, Bosque County, Texas. No claim or suit may be brought against GEARENCH, arising out of the sale and/or use of the tool, or arising out of the terms of this warranty, except in such forum. Purchase and/or use of the GEARENCH tool makes you subject to the benefits and limitations of this limited warranty. Accordingly, any writ, judgment or other enforcement, obtained from a jurisdiction, county, parish, state or federal court or other country, other than that from the forum identified above, shall be void and unenforceable against GEARENCH.

**Arbitration Clause**

In the event of dispute or claim arises out of the sale and/or use of the GEARENCH tool that is the subject of this limited warranty, or arises out of the interpretation or enforcement of the terms and conditions of this limited warranty, such dispute shall be submitted to binding arbitration pursuant to the rules of the American Arbitration Association. If required to accomplish the purpose of this Arbitration clause, the purchaser hereby expressly waives any right to demand trial by jury.

**Complete Agreement**

This express limited warranty contains the entire agreement regarding express or implied warranties related to the GEARENCH tool that is the subject of it. No writing or language contained in the purchase order or any other document of the purchaser, or invoice of GEARENCH or any intermediate seller, shall be construed as modifying, in any way, the rights and liabilities contained in this limited warranty. GEARENCH expressly disclaims any obligations expressed in any customer purchase order or document that are contrary to the terms and limitations of this warranty.

**Severability**

If any term or limitation contained in this limited warranty is deemed unenforceable by law, then the term shall be severed from the remaining portions of the limited warranty which shall remain enforceable.

All communications to GEARENCH regarding the use of the tool and any aspect of the sale of the tool of this limited warranty should be addressed to GEARENCH.

GEARENCH · 4450 South Highway 6 · P.O. Box 192 · Clifton, TX 76634

## **Safe Practices and Procedures**

### **Responsibility**

“It is the responsibility of the employer to train the employee in the proper selection and usage of tools, chains, etc., and to ensure that they are selected and used in that manner. In many instances, injury results because it is assumed that anybody knows how to use common hand tools. Observations and the record show that this is not the case. A part of every job instruction program should therefore be detailed training in the proper use of hand tools (and of all other special tools and equipment needed to accomplish the job).” - (Source: National Safety Council)

“Employers are responsible for the safe condition of tools and equipment used by employees, including tools and equipment which may be furnished by employees.” - (Source: OSHA 1910.242A)

### **Replacement Parts**

Use only PETOL™ & TITAN™ replacement parts - no other parts are of comparable strength, quality and interchangeability.

### **Safety**

While we pride ourselves on the quality and dependability we build into GEARENCH™ tools and products, we caution users that it is only prudent to know and follow the simple rules of safety when using our products, or anyone else's.

Always follow safe practices and procedures in accordance with the recommendations of OSHA, The National Safety Council (NSC), The Hand Tools Institute (HTI), The National Association of Chain Manufacturers (NACM), The International Association of Drilling Contractors (IADC), Etc. All applicable Governmental rules, regulations or restrictions, now in effect or which may be promulgated, take precedence over the suggestions in this publication. The information in this publication is designed to supplement standard safe practices and procedures, not in lieu of, or replacement thereof.

## **Safe Practices**

Failure to observe one or more of the following five safe practices accounts for most hand and powered tool accidents:

1. ALWAYS WEAR SAFETY GOGGLES TO PROTECT EYES
2. SELECT THE RIGHT TOOL FOR THE JOB
3. KEEP TOOLS IN GOOD CONDITION
4. USE TOOLS CORRECTLY
5. KEEP TOOLS IN A SAFE PLACE

Persons in any area where hand or powered tools are being used must always wear safety goggles.

Never strike wrenches and tools with hammers or other objects.

All tools should be kept clean, inspected on a regular basis, and replaced when they show signs of wear.

Be especially careful not to place yourself in a position that could result in bodily injury in the event of a failure. See diagram on page 18.

READ SAFE PRACTICES AND PROCEDURES MANUAL, CATALOG INFORMATION, AND PRODUCT LABELING PRIOR TO OPERATION.

## **Responsibility of Distributors**

IT IS THE RESPONSIBILITY OF THE PURCHASERS OF GEARENCH PRODUCTS TO CONVEY THE INFORMATION IN THIS PUBLICATION AND ANY OTHER INFORMATION RELATING TO THE INDIVIDUAL PRODUCT, THROUGH THE CHANNELS OF DISTRIBUTION, DOWN TO AND INCLUDING THE INDIVIDUAL USING THE PRODUCT

### ***NOTE:***

**In view of the fact that the actual use determines whether safety requirements have been met, the ultimate responsibility to comply rests with the end user.**

## **Tong and Vise Chain Inspection**

The service life of leaf chains can be altered by a variety of adverse operating conditions. The following information discusses the most important of these conditions for consideration when operating or scheduling replacement of leaf chain systems.

### **Overloading / Shock Loads / Side Loading**

Attempting to “inch loads which are beyond the rated capacity of the tool.

Striking the tool with a hammer or other object while force is being exerted in an attempt to loosen a “frozen” joint.

Side pull can be caused by pulling or pushing on the tong in a direction that is not along a perpendicular plane, unlevelled mounting of the tong or vise, inadequate support of the part being broken out, and improper seating of the part being broken out in the tong or vise. Improper seating will occur when the diameter of the part is not consistent within the width of the tong or vise jaw.

### **Environmental Conditions**

Wrench chains operate in widely varying environments, from wet outdoor conditions to mildly or highly corrosive industrial atmospheres. They can also be exposed to abrasives such as sand or grit.

The possible effects include:

Moisture - Corrosion and rust reduce chain strength by causing pitting and cracking.

Temperature - Very cold temperatures reduce chain strength by embrittlement.

Chemical Solutions or Vapors - Corrosive attack of the chain components’ grain structure and/or the mechanical connections between the chain components (crevice corrosion) may occur. Cracking often is microscopic. Propagation to complete failure can be eventual or sudden.

Abrasives - Accelerated wearing and scoring of the articulating chain members (pins and plates) may occur, with a corresponding reduction in chain strength. Due to inaccessibility of the bearing surfaces (pin surfaces and plate apertures), wear and scoring are not readily noticeable.



These conditions, when coupled with normal chain wear and inherent residual stress (normally in the chain as constructed), can result in environmentally assisted failure. It is impossible to predict chain life under complex conditions, as the degree of hostility and its effects are dependent on many variables such as temperature, time of exposure, concentration of corrosive atmosphere or medium, degree of abrasive wear, etc. Establishing the degree and frequency of unpredictable dynamic loading is also difficult.

### **Normal Life Expectancy**

A leaf chain's normal life expectancy can be expressed as a maximum percent of elongation. This is generally between 2% and 3% of pitch. As the chain flexes back and forth, the bearing joints (pins and inside link plates) gradually wear from articulation. As with all steel bearing surfaces, the precision hardened steel joints of leaf chain require a constant film of oil between mating parts to prevent wear and to resist corrosion.

### **Lubrication**





One of the most important but often-overlooked factors is adequate lubrication. In addition to reducing internal friction, maintaining a film of oil on all chain surfaces will inhibit rusting and corrosion. This is important as corrosion of highly stressed, hardened steel chain components can cause a major reduction in the load capacity of leaf chain and result in link plate cracking.

Protection from corrosion is important in storage as well as in service. The factory lubricant applied to PETOL™ Chain is a "Fingerprint Neutralizing Water-Displacing Corrosion Preventative". This is an excellent rust and corrosion inhibitor for chains in storage. When installing these chains new, do not attempt to steam clean or degrease this lubricant. A grade of SAE 30 or 40 weight, non-detergent motor oil should be used as supplemental lubricant and a film of this oil should be maintained on all surfaces and internal bearing joints. Also, do not attempt to paint new chains. Though painting may help inhibit corrosion, it will seal off critical clearances and restricts oil from reaching the pin surfaces where it is needed for good joint lubrication.

When operating in dusty environments, lubricated chains will accumulate a paste-like buildup of grime. At periodic intervals, this buildup should be removed by cleaning and the chain should be immediately re-lubricated. Do not use caustic or acid type cleaners; use a stiff brush and a certified safe petroleum base solvent.

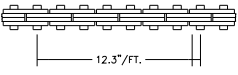
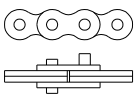
### **Periodic Inspection List for PETOL™ Special Chain**

1. PRIOR TO EACH USE, LEAF CHAIN AND TOOLS SHOULD BE INSPECTED FOR SERVICEABILITY AND LUBRICATION.
2. USE ONLY PETOL™ AND TITAN™ REPLACEMENT PARTS - NO OTHER PARTS ARE OF COMPARABLE STRENGTH, QUALITY, AND INTERCHANGEABILITY.

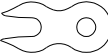
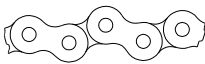
APPEARANCE AND/OR SYMPTOM	PROBABLE CAUSE	CORRECTION
<p>Excessive Length (Elongation)</p> 	<p>Normal wear</p> <p>Permanent deformation (stretch) from overload</p>	<p>Replace chain</p> <p>Replace chain and correct cause of overload</p>
<p>Abnormal Protrusion of Pins</p> 	<p>Overloading</p> <p>Inadequate lubrication</p> <p>Side loading</p>	<p>Replace chain and correct cause of overload</p> <p>Replace chain and improve lubrication</p> <p>Replace chain and correct cause of side load</p>
<p>Cracked Plates (Fatigue)</p> 	<p>Overloading</p> <p>Side loading</p>	<p>Replace chain and correct cause of overload</p> <p>Replace chain and correct cause of side load</p>
<p>Arc-Like Cracked Plates (Stress Corrosion)</p> 	<p>Severe rusting or exposure to acidic or caustic medium, plus static stress at press fit between pin and plate</p>	<p>Replace chain and protect from hostile environment</p>
<p>Enlarged Holes</p> 	<p>Overloading</p>	<p>Replace chain and correct cause of overload</p>
<p>Cracked Plates (Corrosion Fatigue) Perpendicular to Pitch Line, plus rust or other evidence of chemical corrosion</p> 	<p>Corrosive environment</p>	<p>Replace chain and protect from hostile environment</p>
<p>Fractured Plates (Tension Mode)</p> 	<p>Overloading</p>	<p>Replace chain and correct cause of overload</p>
<p>Tight Joints</p> 	<p>Dirt or foreign substance packed in joints</p> <p>Corrosion and rust</p> <p>Bent pins</p>	<p>Clean and relube</p> <p>Replace chain and protect from hostile environment</p> <p>Replace chain</p>

## **Safety Precautions**

1. Always wear safety goggles to protect eyes.
2. Select the right tool for the job.
3. Keep tools in good condition.
4. Use tools correctly.
5. Keep tools in a safe place.
6. Wear protective clothing, gloves and safety shoes as appropriate.
7. Use lengths of assembled chain. Do not build lengths from individual components.
8. Do not attempt to rework damaged chain by replacing only the components obviously faulty. The entire chain may be compromised and should be discarded.
9. Never electroplate assembled leaf chains or components. Plating will result in failure from hydrogen embrittlement.
10. Do not weld any chain or component. Welding spatter should never be allowed to come into contact with chain or components.
11. Leaf chains are manufactured exclusively from heat-treated steels and therefore must not be annealed. If heating a chain with a cutting torch is absolutely necessary for removal, the chain should not be reused.
12. Inspect chains frequently and regularly for link plate cracking, pin turning, pin protrusion and corrosion.
13. Use only PETOL™ & TITAN™ replacement parts to ensure proper strength.

## **Installation**

### **Location**

The PETOL™ HYDRA-TORK™ Unit should be located in an area with adequate room to work the downhole tools. The unit may be located indoors or outdoors upon solid ground or a finished shop floor. No special foundation is required.

### **Setup**

Locate the hydraulic power unit in a convenient location and connect the hoses to the hydraulic cylinder.

## **Operation**

### **Controls**

Use a hydraulic pressure gauge on the power unit to indicate the system pressure in psi. The torque produced by the PETOL™ Drill Pipe Tongs is dependent on the hydraulic pressure and the diameter. A conversion chart for equating the hydraulic pressure in psi to the torque output in foot-pounds is on the following page.

**WARNING: Never operate the tong with a pressure higher than required to perform the make up or break out operation. Operation at excessive pressure may damage the downhole tool and/or injure personnel.**

## Torque – Pressure Conversion Chart

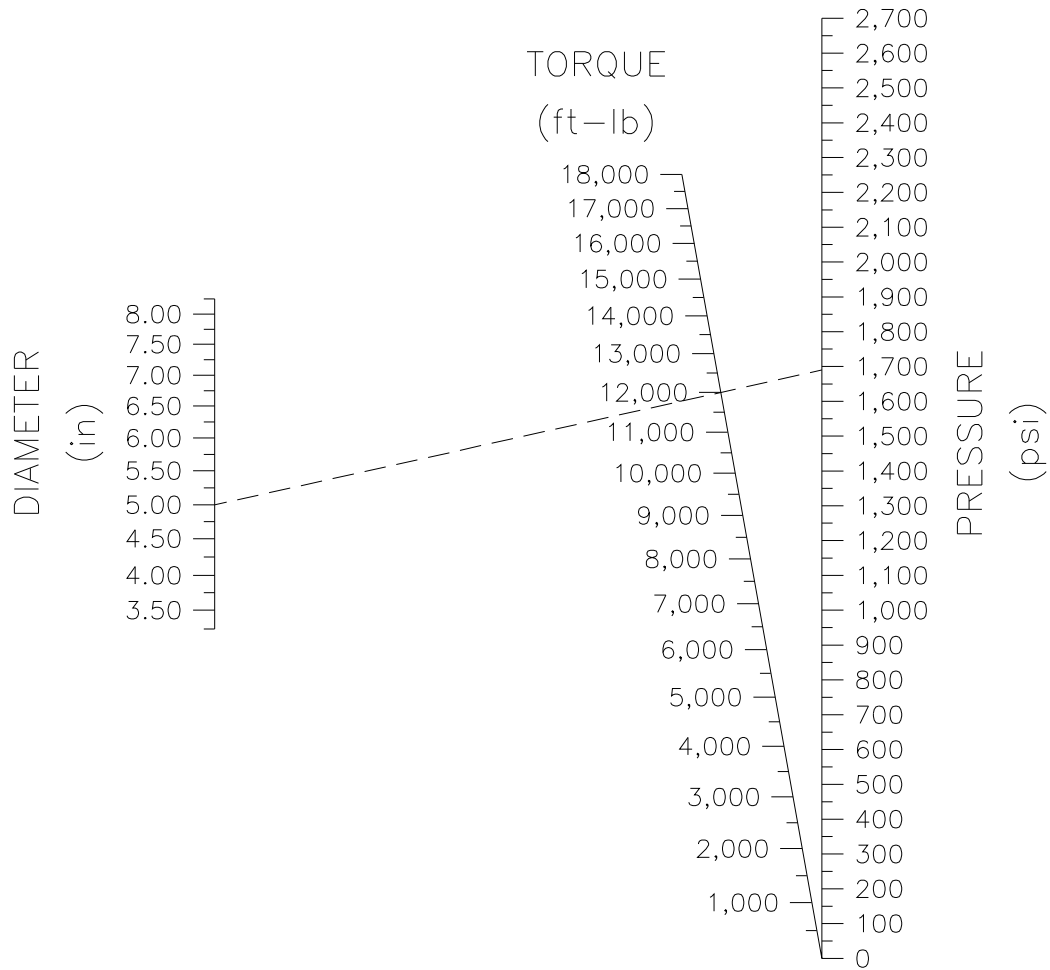

To use chart:

Draw a line from the diameter of the pipe through the desired torque. Read the hydraulic pressure from the right hand column.

## Chain Selection

The following table indicates the chains required for various diameters. The chains are selected by adding or subtracting sections of chain.

Chain Part Number	Diameter Range
151-45-07D	3 – 3 3/4
151-45-09D	3 3/4 – 4 1/2
151-45-11D	4 1/2 – 5 3/8
151-45-13D	5 3/8 – 6 1/4
151-45-15D	6 1/4 – 7
151-45-17D	7 1/16 – 8 1/4

**Warning:** Wrong chain selection could result in failure. See chain selection table above and chain selection guide on the following page.

### Tong adjustment

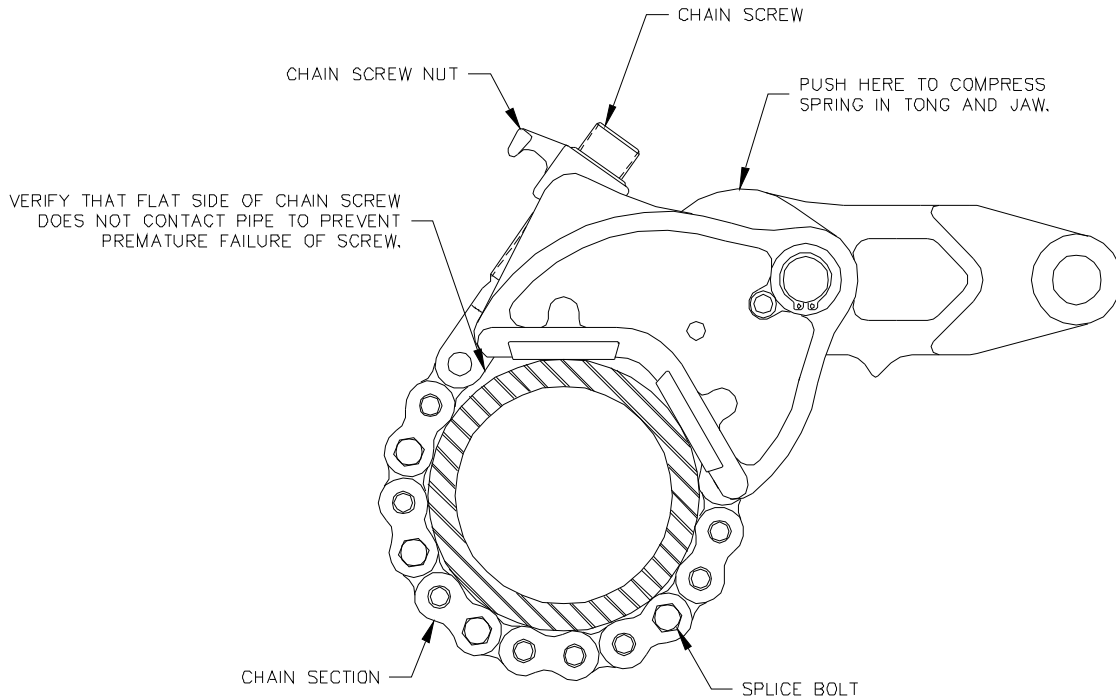

# Chain Identification Guide

2 LINK SECTION

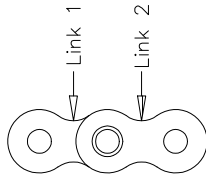

5 LINK SECTION

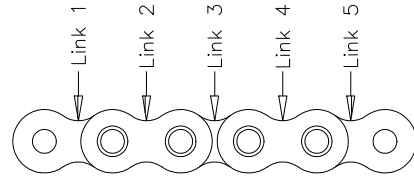

## CHAIN ASSEMBLY

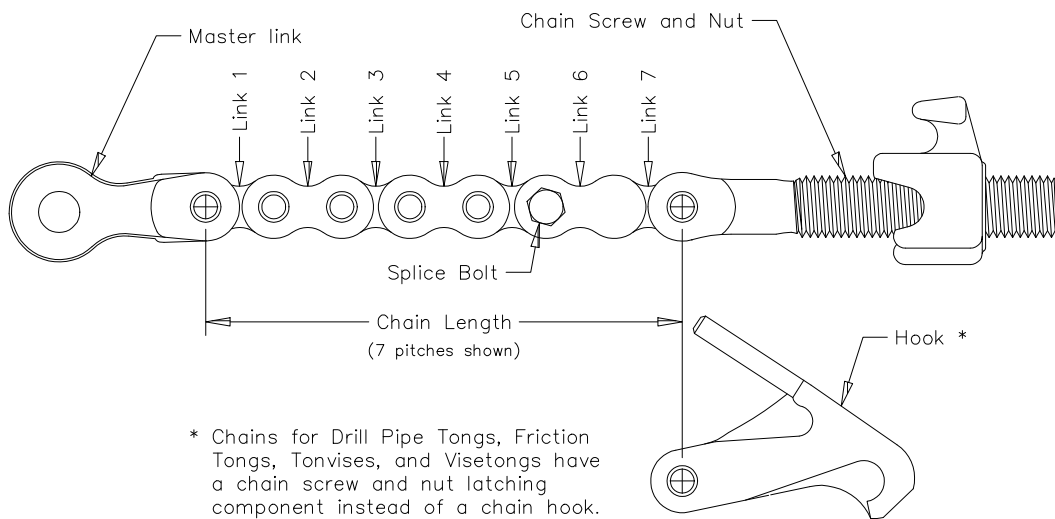

## THIS IS WHAT A CHAIN PART NUMBER TELLS YOU

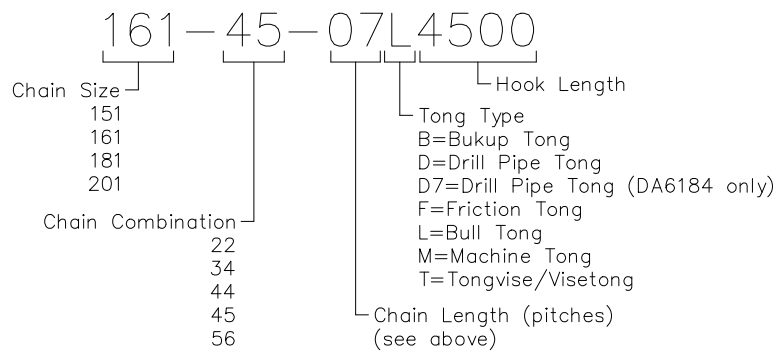



## **Loading**

To load the downhole tool in the unit, adjust the vee-saddles to support the tool. Set the tool into the unit. Position the tongs for make up or break out as needed and set the tongs onto the tool. Adjust the tongs as described and latch the tong chains.

*CAUTION: The vee-saddles must be used to support the tool while torquing.*

## **Tong Adjustment**

Add or remove chain sections as needed using the splice bolts in the chains. Push on the top of the jaw to fully compress the spring inside the jaw. **Adjust the chain screw nut so that the chain is as tight as possible** and fit into the lugs in the jaw.

**Warning: Flat side of chain screw must not make contact with the workpiece. Contact could result in failure. Contact is due to improper chain selection. See selection guide for proper chain and description.**

## **Breaking Out**

Load the tool and adjust the tongs as described above. Fully ratchet the tong by extending the cylinder. Set the system pressure to a minimum. Retract the cylinder. When the tong stops, begin increasing the system pressure. Keep increasing the system pressure until the connection is broken loose **or the working load of the tong is reached. Do not exceed the rating of the tong. Consult with GEARENCH™ as needed for help with the toughest break out jobs.** After the initial break out, ratchet the tong fully and then alternately extend and retract the cylinder until the connection is fully loosened.

## **Making Up**

Load the tool and adjust the tong and vise as described above. Make up the connection hand tight using TITAN™ Chain Tongs. Preset the system pressure to obtain the desired torque if possible. Retract the cylinder. If the cylinder fully retracts without stalling, cycle the tong (extend / retract). Continue until the cylinder stalls or until the desired pressure is obtained.

**Warning: Do not stand in line with the tongs or chains during operation.**

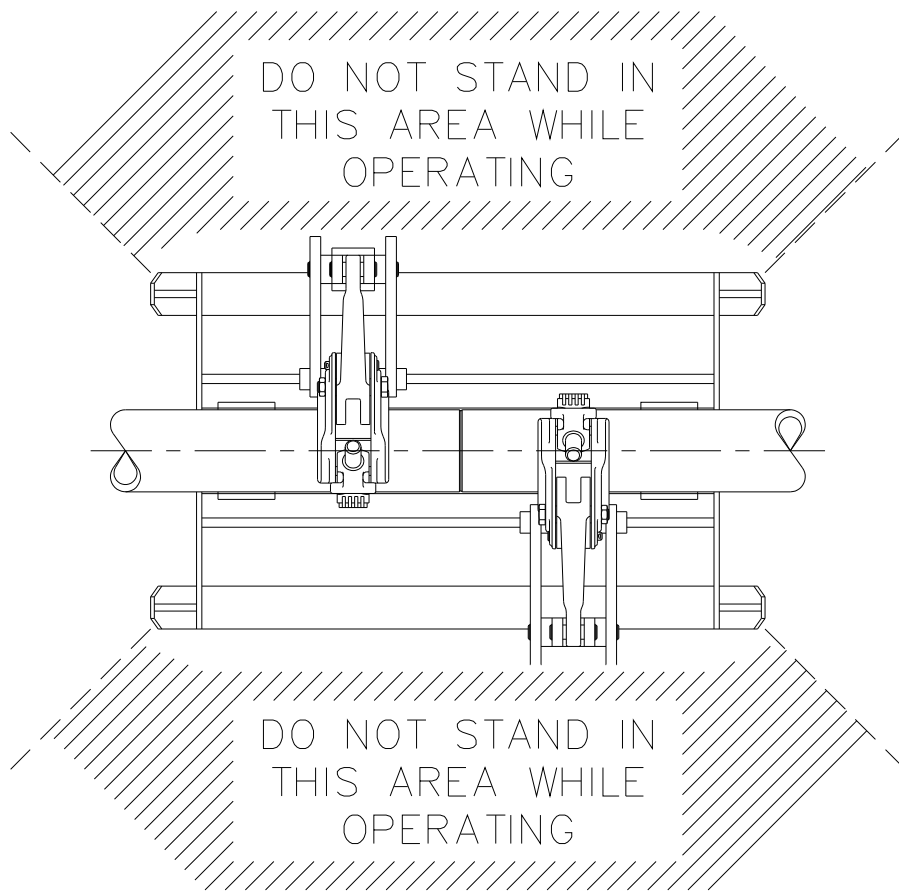

## **Parts List**

The following drawings, diagrams, and parts lists describe all parts which may be needed as replacement items. Where appropriate, standard industrial and hydraulic components have been used. Should a standard industrial item need replacing, the item may be purchased locally. To assist you in obtaining parts, the OEM component manufacturer and model numbers are shown on the parts list. Of course, all replacement parts will be supplied by GEARENCH™ if you prefer to order from us.

**All tong, vise, and chain components are manufactured only by GEARENCH. DO NOT ATTEMPT TO SUBSTITUTE THESE COMPONENTS. The unit will not work properly unless these components are matched to the specific application. Consult our factory as your requirement changes. Any non-GEARENCH substitutions of these components void all warranties and subject the user to assumption of liabilities resulting from subsequent use.**

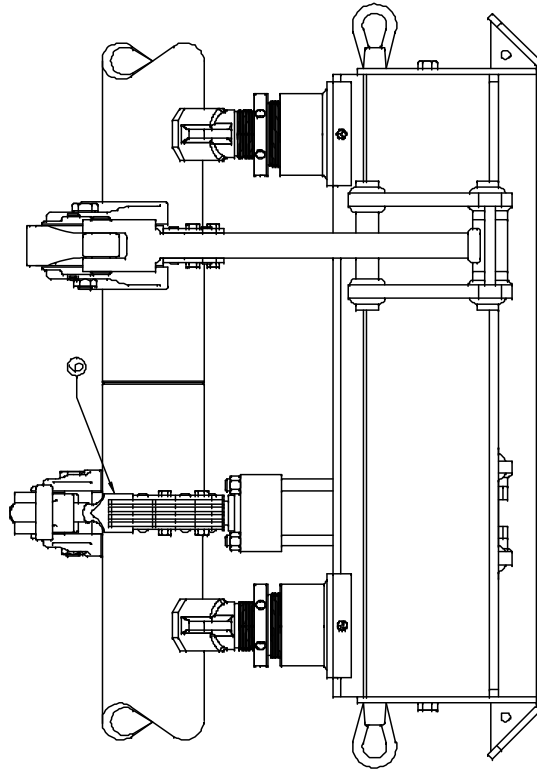
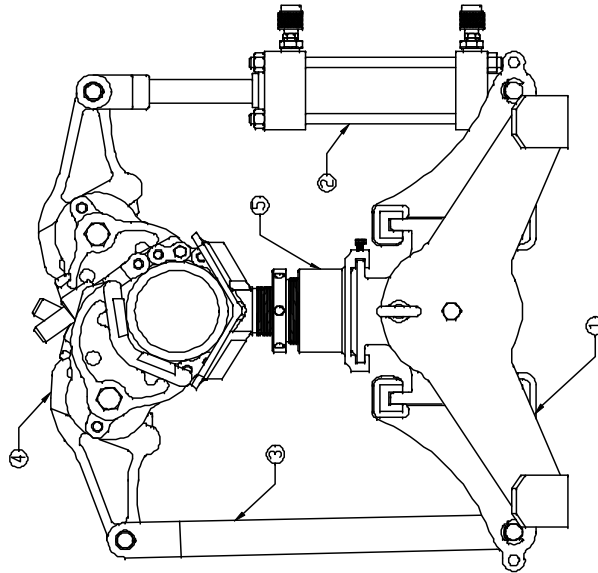

### Final Assembly

Item	Qty.	Part Number	Description	Notes
1	1	UB4174	Base assembly	
2	1	UC4174	Cylinder assembly	See page 21
3	1	UK4174	Backup assembly	See page 22
4	2	DA4174-L08	Tong assembly	See page 23
5	2	UHVSA-4174	Vee saddle assembly	See page 24
6	2	151-45-17D	Chain assembly	See page 25

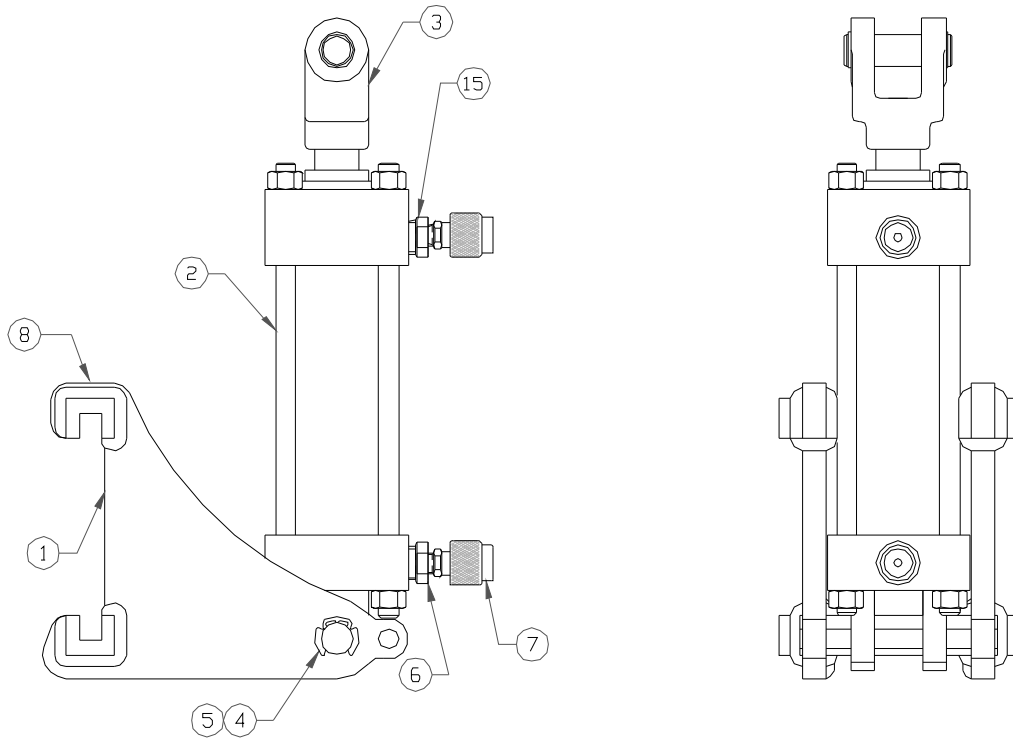

### Cylinder Assembly

Item	Qty.	Part Number	Description	Make / Model	Notes
1	1	UC4174-A	Arm		
2	1	UC4174-C	Cylinder	Vickers/Aeroquip TG10GACA1AA08000	
3	1	UC4174-E	Rod clevis	Vickers/Aeroquip S-662-10	Or equal
4	1	HP372	Arm-cylinder pin		
5	2	HXKR100	Klipring	Waldes-Truarc 5304-100	Or equal
6	1	UHCH-F41	Reducer bushing	Weatherhead C3109X12X6	Or equal
7	2	UHCH-Q05	Quick connect	Enerpac CR-400	Or equal
8	1	HXS017	Hex bolt	5/16-18UNC x 3/4	

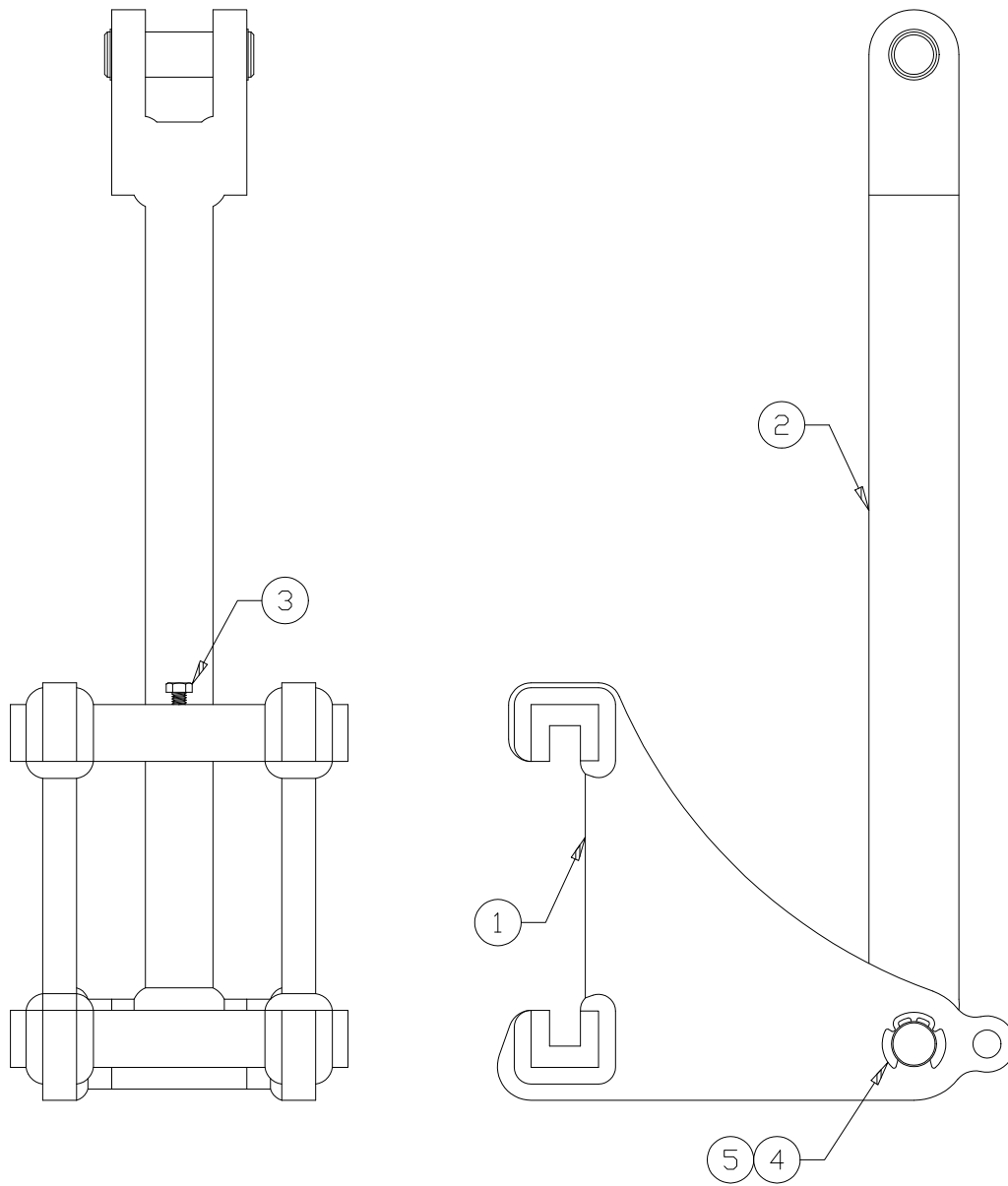

**Backup assembly**

Item	Qty.	Part Number	Description	Notes
1	1	UC4174-A	Arm	
2	1	U4174-LK	Link arm	
3	1	HXS012	Hex bolt	5/16-18UNC x 3/4
4	1	HP372	Arm – link pin	
5	2	HXKR100	Klipring	Waldes – Truarc 5304-100

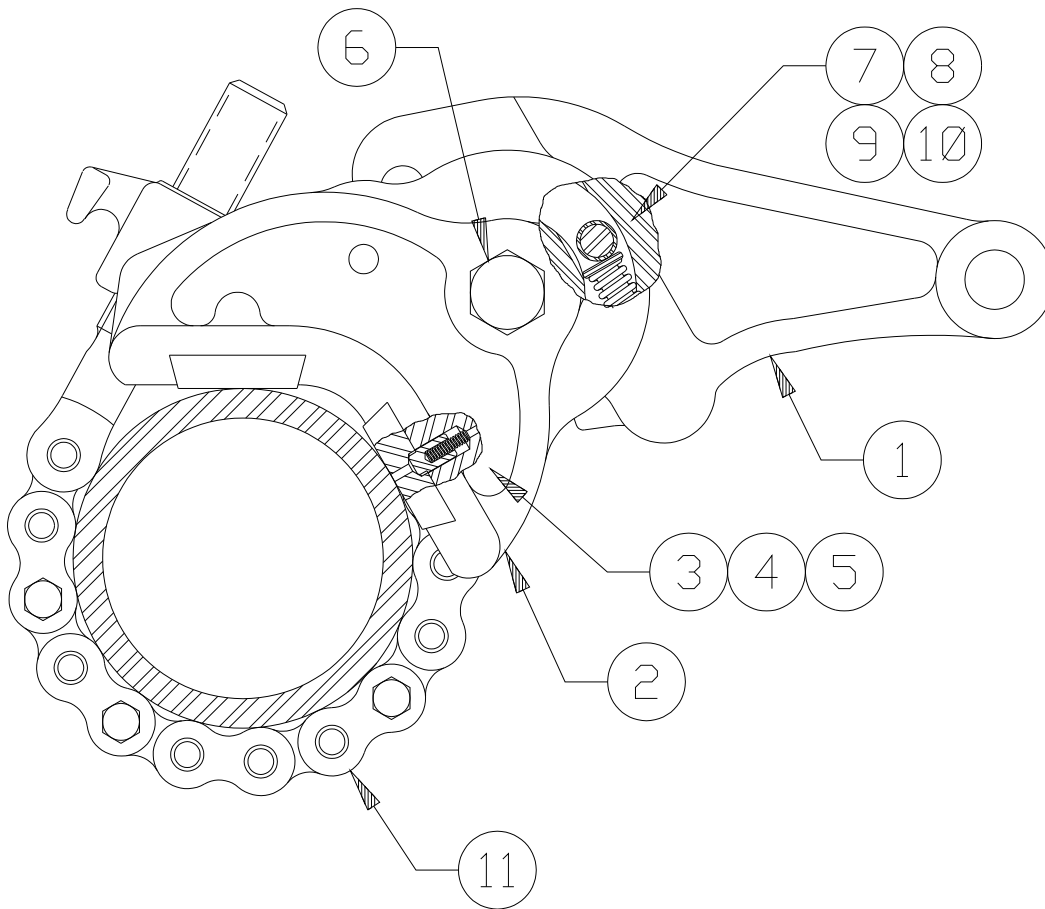

### Tong assembly

Item	Qty.	Part Number	Description	Notes
1	1	DH4174-L08	Handle	
2	1	DJ4174	Jaw	
3	4	HI04D	Diamond point insert	Standard
3a	4	HI04K	Knurled insert	Optional
4	4	HP903	Insert key	
5	4	HS20S	Insert key spring	
6	1	HB35	Jaw bolt and nut	
7	1	HS19	Spring	
8	1	HP238	Spring pin and cotter	
9	1	HU40	Spring pin bushing	
10	1	HG13	Spring guide	
11	1	151-45-17D	Chain assembly	See page 22

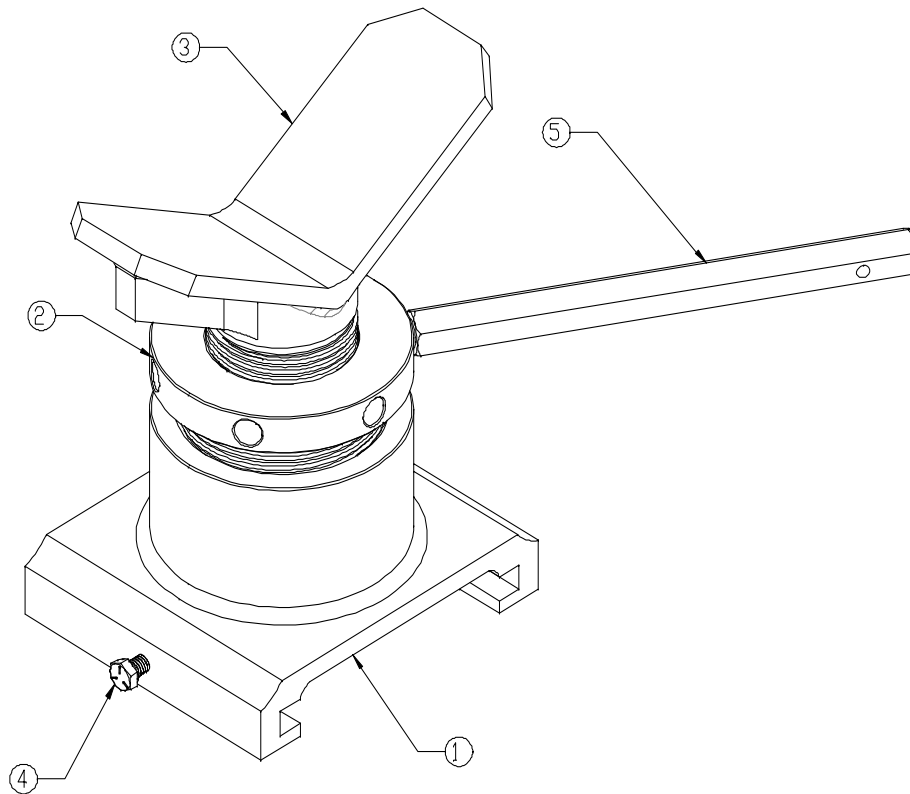

### Vee Saddle Assembly

Item	Qty.	Part Number	Description	Notes
1	1	UHVSB-4174	Base	
2	1	UHVSN-4174	Nut	
3	2	UHVSH-115H	Head	
4	1	HXS012	Hex bolt	5/16-18UNC x 7/8
5	1	HP951	Nut Lever	



### PETOL™ Special Chain Parts List

<b>Item</b>	<b>Qty</b>	<b>Part Number</b>	<b>Description</b>	<b>Notes</b>
1	1	HP235	Master link – handle pin	
2	1	HM01-45	Master link	
3	1	HP237	Master link – chain pin	
4	1	151-45-05	Special chain only	
5	2	151-45-04	Special chain only	
6	2	151-45-02	Special chain only	
7	4	HB48	Splice bolt and nut	
8	1	HV02-45	Chain screw	
9	1	HN01	Chain screw nut	
10	1	HP236	Chain screw – chain pin	