

Petol Hydra-Tork

U118-13

Operating Manual

Gearench
P.O. Box 192
4450 South Highway 6
Clifton, Texas 76634
Phone: (254) 675-8651
Fax: (254) 675-6100

© 2005 by GEARENCH. All rights reserved

Form U118-13 revision 6/6/05

Table of Contents

Petol U118-13 Hydra-Tork Description.....	1
Warranty	2
Safe Practices and Procedures.....	4
Responsibility	4
Replacement Parts	4
Safety.....	4
Safe Practices	4
Safety Sources and Publications.....	5
Responsibility of Distributors.....	6
Tong and Vise Chain Inspection	6
Overloading / Shock Loads / Side Loading.....	6
Environmental Conditions.....	6
Normal Life Expectancy.....	7
Lubrication	7
Periodic Inspection List for Petol Special Chain.....	8
Safety Precautions	10
Installation.....	11
Location.....	11
Setup.....	11
Electrical Wiring	11
Startup	11
Operation.....	12
Controls	12
TORQUE-PRESSURE CONVERSION.....	13
Loading.....	15
Vise and Tong Adjustment.....	15
Breaking Out	16
Making Up.....	16
Calibration.....	16
Recommended Calibration Setpoints	17
Parts List.....	18
Final Assembly Parts List.....	19
Console Assembly Parts List.....	21
Hydraulic Schematic	22
Control Panel Parts List.....	24
Main Electrical Panel Parts List	25
Cylinder Carriage Parts List	27
Vee Saddle Assembly Parts List.....	29
Vise Assembly Parts List.....	30
Tong Assembly Parts List	31
Petol Special Chain Parts List	32
Electrical Schematic	33

Petol U118-13 Hydra-Tork Description

The U118-13 Petol Hydra-Tork unit was designed for making up and breaking out downhole tools. It is rated for operation on 4" to 24" diameters with a maximum working load of 90,000 ft-lbs.

The Petol Pulldown Visetong and Petol Tongvise are adjusted to the different ODs within their range by pulling the Petol Special Chain through the jaw and engaging a cam lock lever. No addition or removal of chain sections is required.

The U118-13 also offers the following features:

A shock mounted hydraulic console not attached to the base to provide maximum flexibility in the setup and location of the power unit for efficient use of shop space. All controls are 24 volts AC, NEMA type 13.

The tong cylinder and vise base are mounted on tracks for switching from make up to break out.

One adjustable vee-saddle mounted on the hydra-tork base for added support. This vee-saddle is also mounted on tracks for easy adjustment.

An integral tong lift cylinder to raise and lower the tong from the tool without using an over-head hoist.

Digital torque display for direct reading of torque in 10 foot-pound increments with an auxiliary output for a recorder at 1 volt / 20,000 foot-pounds.

Operating voltages are 208/240/460 volts, 3 phase, 10 horsepower. 277/380 volts, 3 phase, 10 horsepower is available upon request.

Warranty

What Is Covered

Gearench tools are expressly warranted to you, the purchaser, to be free of defects in material and workmanship.

How Long Coverage Lasts

This express warranty lasts for the lifetime of the GEARENCH tool. Warranty coverage ends when the tool becomes unusable for reasons other than defects in workmanship or material.

How Can You Get Warranty Service

To obtain the benefit of this warranty, contact a GEARENCH sales representative in Clifton, Texas.
GEARENCH · 4450 South Highway 6 · P.O. Box 192 · Clifton, TX 76634

What Will We Do To Correct Problems

Warranted products will be repaired or replaced, at GEARENCH's option, and returned at no charge to you, the original purchaser; or, if after three attempts at repair or replacement during the warranty period, the product defect in material or workmanship persists, you can elect to receive a full refund of your original purchase price for the product.

What Is Not Covered

Defects, failures or conditions that are due to normal wear and tear, abuse or misuse, are not covered by this limited warranty. In addition, this limited warranty is in lieu of all other warranties, express or implied, verbal or written. To the maximum extent allowed by law GEARENCH disclaims all implied warranties, including implied warranties of merchantability and/or fitness for a particular purpose. GEARENCH also specifically denies any liability for any incidental damages and/or consequential damages, including but not limited to property damage to property other than the product itself, loss of sales profits, down time, costs or any other damages measurable in money, whether or not included in the foregoing enumeration.

Please be advised that some states do not allow the exclusion or limitation of incidental or consequential damages, so this limitation or exclusion may not apply to you. This warranty gives you specific rights, and you may also have other rights, which vary from state to state, province to province, or country to country.

Are Personal Injuries Covered

In the event you, someone working for you, or any other person sustain a personal injury as a result of using the GEARENCH tool, GEARENCH limits its potential liability for such a claim or injury to the fullest extent allowed by law, and disclaims and denies any liability for such personal injury.

Please be advised that some states do not allow the exclusion or limitation of liability for personal injuries, so the above limitation or exclusion may not apply to you, or the individual claiming injury.

No Other Express Warranty Applies

This GEARENCH LIMITED WARRANTY is the sole and exclusive warranty, express or implied for GEARENCH products. No employee, agent, dealer or other person is authorized to alter, modify, expand or reduce the terms of this warranty or to make any other warranty on behalf of GEARENCH.

Law Applicable

All matters related to the sale and/or use of the GEARENCH tool that is the subject of this limited warranty, along with the construction and enforcement of the terms of this limited warranty itself, shall be subject to the substantive and procedural laws of the state of Texas, not the conflicts of laws provisions of Texas, but rather the laws of Texas themselves.

Forum Selection Clause

Any dispute arising out of the sale and/or use of the GEARENCH tool that is the subject of this limited warranty shall be presented in the form of a claim or lawsuit to the offices of GEARENCH in Clifton, Bosque County, Texas. No claim or suit may be brought against GEARENCH, arising out of the sale and/or use of the tool, or arising out of the terms of this warranty, except in such forum. Purchase and/or use of the GEARENCH tool makes you subject to the benefits and limitations of this limited warranty. Accordingly, any writ, judgment or other enforcement, obtained from a jurisdiction, county, parish, state or federal court or other country, other than that from the forum identified above, shall be void and unenforceable against GEARENCH.

Arbitration Clause

In the event of dispute or claim arises out of the sale and/or use of the GEARENCH tool that is the subject of this limited warranty, or arises out of the interpretation or enforcement of the terms and conditions of this limited warranty, such dispute shall be submitted to binding arbitration pursuant to the rules of the American Arbitration Association. If required to accomplish the purpose of this Arbitration clause, the purchaser hereby expressly waives any right to demand trial by jury.

Complete Agreement

This express limited warranty contains the entire agreement regarding express or implied warranties related to the GEARENCH tool that is the subject of it. No writing or language contained in the purchase order or any other document of the purchaser, or invoice of GEARENCH or any intermediate seller, shall be construed as modifying, in any way, the rights and liabilities contained in this limited warranty. Gearench expressly disclaims any obligations expressed in any customer purchase order or document that are contrary to the terms and limitations of this warranty.

Severability

If any term or limitation contained in this limited warranty is deemed unenforceable by law, then the term shall be severed from the remaining portions of the limited warranty which shall remain enforceable.

All communications to GEARENCH regarding the use of the tool and any aspect of the sale of the tool of this limited warranty should be addressed to GEARENCH.

GEARENCH · 4450 South Highway 6 · P.O. Box 192 · Clifton, TX 76634

Safe Practices and Procedures

Responsibility

"It is the responsibility of the employer to train the employee in the proper selection and usage of tools, chains, etc., and to ensure that they are selected and used in that manner. In many instances, injury results because it is assumed that anybody knows how to use common hand tools. Observations and the record show that this is not the case. A part of every job instruction program should therefore be detailed training in the proper use of hand tools (and of all other special tools and equipment needed to accomplish the job)." - (Source: National Safety Council)

"Employers are responsible for the safe condition of tools and equipment used by employees, including tools and equipment which may be furnished by employees." - (Source: OSHA 1910.242A)

Replacement Parts

Use only PETOL & TITAN replacement parts - no other parts are of comparable strength, quality and interchangeability.

Safety

While we pride ourselves on the quality and dependability we build into GEARENCH tools and products, we caution users that it is only prudent to know and follow the simple rules of safety when using our products, or anyone else's.

Always follow safe practices and procedures in accordance with the recommendations of OSHA, The National Safety Council (NSC), The Hand Tools Institute (HTI), The National Association of Chain Manufacturers (NACM), The International Association of Drilling Contractors (IADC), Etc. All applicable Governmental rules, regulations or restrictions, now in effect or which may be promulgated, take precedence over the suggestions in this publication. The information in this publication is designed to supplement standard safe practices and procedures, not in lieu of, or replacement thereof.

Safe Practices

(Source: The National Safety Council)

Failure to observe one or more of the following five safe practices accounts for most hand and powered tool accidents:

1. ALWAYS WEAR SAFETY GOGGLES TO PROTECT EYES
2. SELECT THE RIGHT TOOL FOR THE JOB
3. KEEP TOOLS IN GOOD CONDITION
4. USE TOOLS CORRECTLY
5. KEEP TOOLS IN A SAFE PLACE

Safety Goggles must always be worn by persons in any area where hand and powered tools are being used.

Never apply excess leverage to a wrench or tool by means of a "Cheater Bar". Never strike wrenches and tools with hammers or other objects.

All tools should be kept clean, inspected on a regular basis, and replaced when they show signs of wear.

Be especially careful not to place yourself in a position that could result in bodily injury in the event of a failure. Brace yourself firmly and pull rather than push when wrenching. (If necessary to push, do so with the flat of the hand rather than gripping around the wrench.)

Never stand under or near loads being hoisted off the ground.

READ SAFE PRACTICES AND PROCEDURES MANUAL, CATALOG INFORMATION AND PRODUCT LABELING PRIOR TO OPERATION.

Spinning and drill pipe chain, cathead chain, and the PETOL Connecting Link attachment are designed for the specific purpose for which the name indicates. Chains and attachments that are to be used for any other purpose should be selected in accordance with the recommendations of ASTM, NACM, Rigger's Handbook, and the commercial chain manufacturer's technical manuals.

Safety Sources and Publications

In the interest of Safety the following sources of Safety information is furnished:

The Hand Tools Institute (HTI)
25 North Broadway
Tarrytown, New York 10591
(914) 332-0040
www.hti.org

The National Safety Council (NSC)
1121 Spring Lake Drive
Itasca, Illinois 60143-3201
(630) 285-1121
www.nsc.org

International Safety Council
1121 Spring Lake Drive
Itasca, Illinois 60143-3201
(630) 285-1121

Responsibility of Distributors

IT IS THE RESPONSIBILITY OF THE PURCHASERS OF GEARENCH PRODUCTS TO CONVEY THE INFORMATION IN THIS PUBLICATION AND ANY OTHER INFORMATION RELATING TO THE INDIVIDUAL PRODUCT, THROUGH THE CHANNELS OF DISTRIBUTION, DOWN TO AND INCLUDING THE INDIVIDUAL USING THE PRODUCT

NOTE:

In view of the fact that the actual use determines whether safety requirements have been met, the ultimate responsibility to comply rests with the end user.

Tong and Vise Chain Inspection

The service life of leaf chains can be altered by a variety of adverse operating conditions. The following information discusses the most important of these conditions for consideration when operating or scheduling replacement of leaf chain systems.

Overloading / Shock Loads / Side Loading

Attempting to "inch loads which are beyond the rated capacity of the tool.

Striking the tool with a hammer or other object while force is being exerted in an attempt to loosen a "frozen" joint.

Side pull on the chain. Side pull can be caused by pulling or pushing on the tong in a direction that is not along a perpendicular plane, unlevel mounting of the vise, inadequate support of the part being broken out, and improper seating of the part being broken out in the tong or vise. Improper seating will occur when the OD of the part is not consistent within the width of the tong or vise jaw.

Environmental Conditions

Wrench chains operate in widely varying environments, from wet outdoor conditions to mildly or highly corrosive industrial atmospheres. They can also be exposed to abrasives such as sand or grit.

The possible effects include:

Moisture - Corrosion and rust reduce chain strength by causing pitting and cracking.

Temperature - Very cold temperatures reduce chain strength by embrittlement.

Chemical Solutions or Vapors - Corrosive attack of the chain components' grain structure and/or the mechanical connections between the chain components (crevice corrosion) may occur. Cracking often is microscopic. Propagation to complete failure can be eventual or sudden.

Abrasives - Accelerated wearing and scoring of the articulating chain members (pins and plates) may occur, with a corresponding reduction in chain strength. Due to inaccessibility of the bearing surfaces (pin surfaces and plate apertures), wear and scoring are not readily noticeable.

These conditions, when coupled with normal chain wear and inherent residual stress (normally in the chain as constructed), can result in environmentally assisted failure. It is impossible to predict chain life under complex conditions, as the degree of hostility and its effects are dependent on many variables such as temperature, time of exposure, concentration of corrosive atmosphere or medium, degree of abrasive wear, etc.. Establishing the degree and frequency of unpredictable dynamic loading is also difficult.

Normal Life Expectancy

A leaf chain's normal life expectancy can be expressed as a maximum percent of elongation. This is generally between 2% and 3% of pitch. As the chain flexes back and forth, the bearing joints (pins and inside link plates) gradually wear from articulation. As with all steel bearing surfaces, the precision hardened steel joints of leaf chain require a constant film of oil between mating parts to prevent wear and to resist corrosion.

Lubrication



One of the most important but often-overlooked factors is adequate lubrication. In addition to reducing internal friction, maintaining a film of oil on all chain surfaces will inhibit rusting and corrosion. This is important as corrosion of highly stressed, hardened steel chain components can cause a major reduction in the load capacity of leaf chain and result in link plate cracking.

Protection from corrosion is important in storage as well as in service. The factory lubricant applied to PETOL CHAIN is a "Fingerprint Neutralizing Water-Displacing Corrosion Preventative". This is an excellent rust and corrosion inhibitor for chains in storage. When installing these chains new, do not attempt to steam clean or degrease this lubricant. A grade of SAE 30 or 40 weight, nondetergent motor oil should be used as supplemental lubricant and a film of this oil should be maintained on all surfaces and internal bearing joints. Also, do not attempt to paint new chains. Though painting may help inhibit corrosion, it will seal off critical clearances and restricts oil from reaching the pin surfaces where it is needed for good joint lubrication.

When operating in dusty environments, lubricated chains will accumulate a paste-like buildup of grime. At periodic intervals, this buildup should be removed by cleaning and the chain should be immediately relubricated. Do not use caustic or acid type cleaners; use a stiff brush and a certified safe petroleum base solvent.

Periodic Inspection List for Petol Special Chain

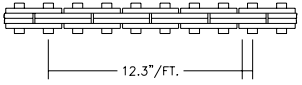
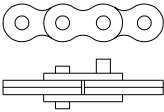
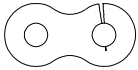
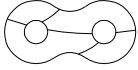
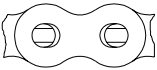
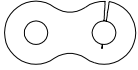
1. PRIOR TO EACH USE, LEAF CHAIN AND TOOLS SHOULD BE INSPECTED FOR SERVICEABILITY AND LUBRICATION.
2. USE ONLY PETOL AND TITAN REPLACEMENT PARTS - NO OTHER PARTS ARE OF COMPARABLE STRENGTH, QUALITY, AND INTERCHANGEABILITY.

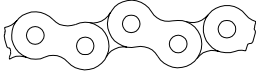
APPEARANCE AND/OR SYMPTOM	PROBABLE CAUSE	CORRECTION
<p>Excessive Length (Elongation)</p> 	<p>Normal wear</p> <p>Permanent deformation (stretch) from overload</p>	<p>Replace chain</p> <p>Replace chain and correct cause of overload</p>
<p>Abnormal Protrusion of Pins</p> 	<p>Overloading</p> <p>Inadequate lubrication</p> <p>Side loading</p>	<p>Replace chain and correct cause of overload</p> <p>Replace chain and improve lubrication</p> <p>Replace chain and correct cause of side load</p>
<p>Cracked Plates (Fatigue)</p> 	<p>Overloading</p> <p>Side loading</p>	<p>Replace chain and correct cause of overload</p> <p>Replace chain and correct cause of side load</p>
<p>Arc-Like Cracked Plates (Stress Corrosion)</p> 	<p>Severe rusting or exposure to acidic or caustic medium, plus static stress at press fit between pin and plate</p>	<p>Replace chain and protect from hostile environment</p>
<p>Enlarged Holes</p> 	<p>Overloading</p>	<p>Replace chain and correct cause of overload</p>
<p>Cracked Plates (Corrosion Fatigue) Perpendicular to Pitch Line, plus rust or other evidence of chemical corrosion</p> 	<p>Corrosive environment</p>	<p>Replace chain and protect from hostile environment</p>
<p>Fractured Plates (Tension Mode)</p> 	<p>Overloading</p>	<p>Replace chain and correct cause of overload</p>
<p>Tight Joints</p> 	<p>Dirt or foreign substance packed in joints</p> <p>Corrosion and rust</p> <p>Bent pins</p>	<p>Clean and relube</p> <p>Replace chain and protect from hostile environment</p> <p>Replace chain</p>

Safety Precautions

1. Always wear safety goggles to protect eyes.
2. Select the right tool for the job.
3. Keep tools in good condition.
4. Use tools correctly.
5. Keep tools in a safe place.
6. Wear protective clothing, gloves and safety shoes as appropriate.
7. Use lengths of assembled chain. Do not build lengths from individual components.
8. Do not attempt to rework damaged chain by replacing only the components obviously faulty. The entire chain may be compromised and should be discarded.
9. Never electroplate assembled leaf chains or components. Plating will result in failure from hydrogen embrittlement.
10. Do not weld any chain or component. Welding spatter should never be allowed to come into contact with chain or components.
11. Leaf chains are manufactured exclusively from heat-treated steels and therefore must not be annealed. If heating a chain with a cutting torch is absolutely necessary for removal, the chain should not be reused.
12. Inspect chains frequently and regularly for link plate cracking, pin turning, pin protrusion and corrosion.
13. Use only PETOL & TITAN replacement parts to ensure proper strength.

Installation

Location

The Petrol Hydra-Tork Unit should be located in an area with adequate room to work the downhole tools. The unit may be located indoors or outdoors upon solid level ground or a finished shop floor. No special foundation is required.

Setup

Locate the hydraulic console in a convenient location and connect the hoses to the main hydraulic cylinder and the lift cylinder.

Electrical Wiring

Connect electrical power to the console at the disconnect switch located in the access door of the main electrical panel at the top of the console. The electrical supply should be made by a qualified electrician in accordance with all applicable local codes and standards. If the unit voltage must be changed to match the available supply voltage (e.g. after relocation), change the motor wiring at the motor in the lower section of the console, change the primary leads on the control transformer in the main electrical panel, change the fuses in the disconnect switch, and change the motor starter heater elements in the main electrical panel. The spare parts list describes the fuses and heater elements needed for all voltages.

Startup

Verify that the oil level is within the operating limits as shown on the console sight glass. **Use Chevron AW-ISO46 or equal (30 gallons).** Turn on the disconnect switch to power up the console. Start the hydraulic pump and immediately press any one of the cylinder control buttons. If the cylinder does not move and if no hydraulic pressure is indicated (1) immediately turn off the power; (2) lock out the power supply to the console; and (3) reverse any two of the power supply leads to obtain the correct pump rotation.

If the main cylinder will only extend and not retract (1) turn off the power; (2) lock out the power to the console; and (3) reverse the hoses attaching the console to the main cylinder.

If the lift cylinder operates opposite from the switch functions (1) turn off the power; (2) lock out the power to the console; and (3) reverse the hoses attaching the console to the lift cylinder.

Cycle the cylinder several times to clear the system of any entrapped air.

Operation

Controls

The operating controls are shown on Figures 1 and 2 on page 16.

The disconnect switch is used to disconnect electrical power to the controls. When this switch is on, the motor may be started.

The **POWER ON** switch will start the hydraulic pump motor. It contains an indicator light to show that the motor is on. The **POWER OFF** switch is used to stop the motor.

The **FILTER** indicator light is used to monitor the hydraulic filter. If this light is on while a cylinder is traveling the hydraulic filter element, located in the lower portion of the console, is dirty and must be replaced. Use **Hycon 0085-MA-010-P element or equal**.

The **LIFT UP** and **LIFT DOWN** buttons are used to control the operation of the tong lift cylinder. Press the **LIFT UP** button to raise the tong off the tool. Press the **LIFT DOWN** button to lower the tong onto the tool.

WARNING: Never operate the tong without making sure that the lift cylinder is fully retracted. Failure to do so could damage the lift cylinder, tong, or downhole tool.

The **LIFT-TORQUE** selector switch changes operation from the tong lift to the main cylinder.

The **TONG RATCHET** and **TONG ENGAGE** buttons are used to control operation of the main cylinder. Press the **TONG ENGAGE** button to apply torque. Press the **TONG RATCHET** button to ratchet the tong back to the pull down position.

The pressure control knob is used to adjust the overall system pressure. Turn the knob clockwise to increase pressure or counter-clockwise to decrease system pressure.

WARNING: Never operate the tong with a pressure higher than required to perform the make up or break out operation. Operation at excessive pressure may damage the downhole tool and/or injure personnel.

The hydraulic pressure gauge is used to indicate the current system pressure in psi. A conversion chart for equating the hydraulic pressure in psi to the torque output in ft-lbs follows:

TORQUE-PRESSURE CONVERSION

TORQUE (ft-lbs)	PRESSURE (psig)	TORQUE (ft-lbs)	PRESSURE (psig)
0	0	30,000	940
10,000	315	31,000	970
11,000	345	32,000	1,000
12,000	375	33,000	1,035
13,000	410	34,000	1,065
14,000	440	35,000	1,095
15,000	470	36,000	1,130
16,000	500	37,000	1,160
17,000	535	38,000	1,190
18,000	565	39,000	1,220
19,000	595	40,000	1,255
20,000	625	45,000	1,410
21,000	660	50,000	1,565
22,000	690	55,000	1,725
23,000	720	60,000	1,880
24,000	750	65,000	2,035
25,000	785	70,000	2,195
26,000	815	75,000	2,350
27,000	845	80,000	2,510
28,000	880	85,000	2,665
29,000	910	90,000	2,820

Hydraulic Console
Figure 1

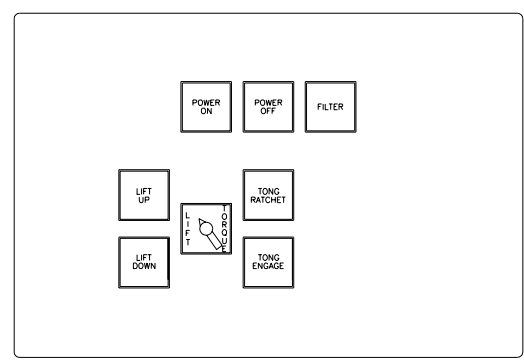
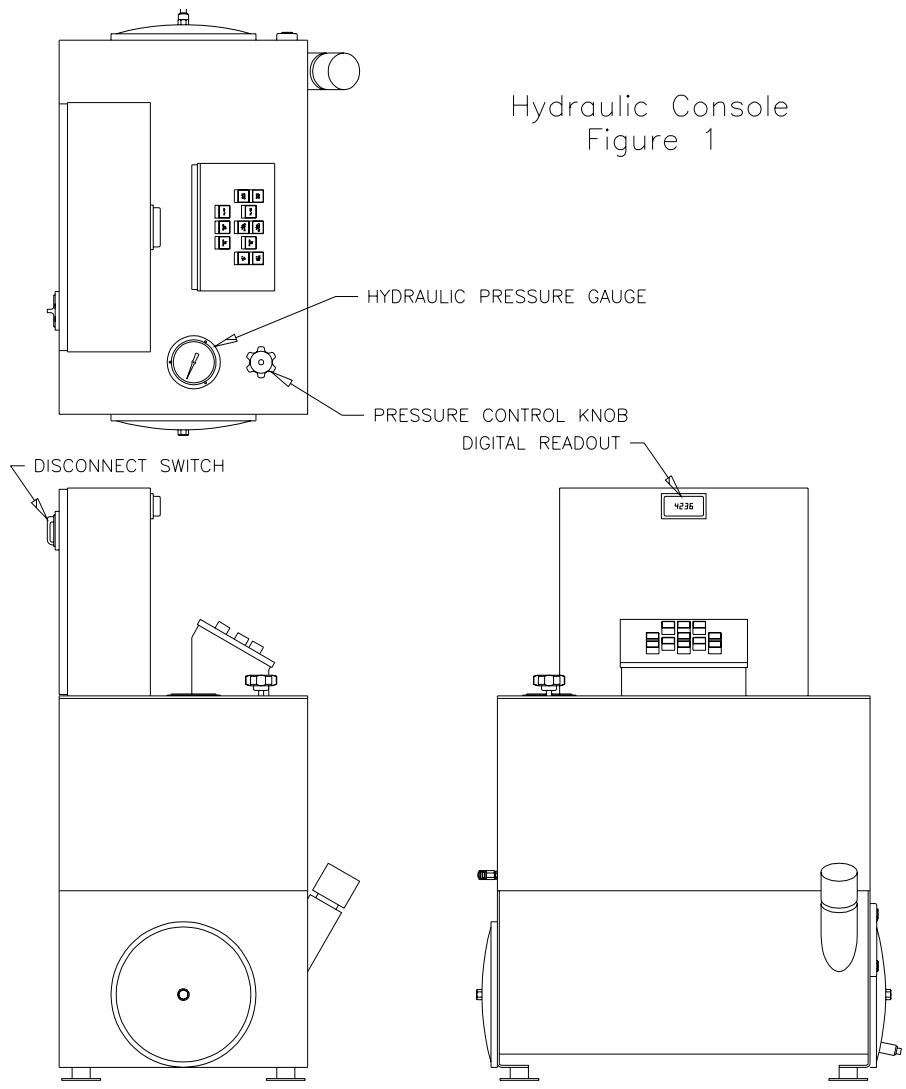

Control Panel (pushbuttons)
Figure 2

Loading

To load the downhole tool in the unit, slide the vise left or right as needed. Adjust the vee-saddle to support the tool when set into the vise. Set the tool into the vise. Position the tong for make up or break out as needed and set the tong onto the tool. Adjust the vise and tong as described and latch the vise chain and tong chain.

CAUTION: The vee-saddles must be used to support the tool while torquing.

Vise and Tong Adjustment

Release the cam lock on the tong and vise by depressing the cam lever and moving the pawl to the unlocked position (see figure). Slide the chain through the tong or vise as needed to latch the chain screw nut into the jaw. Move the pawl lever to the locked position and release the cam lever. Check that the cam lever is latched. Tighten the chain screw nut on the vise until hand tight. Tighten the chain screw nut on the tong until it is hand tight and then loosen the chain screw nut on the tong 1/2 turn to provide proper ratcheting.

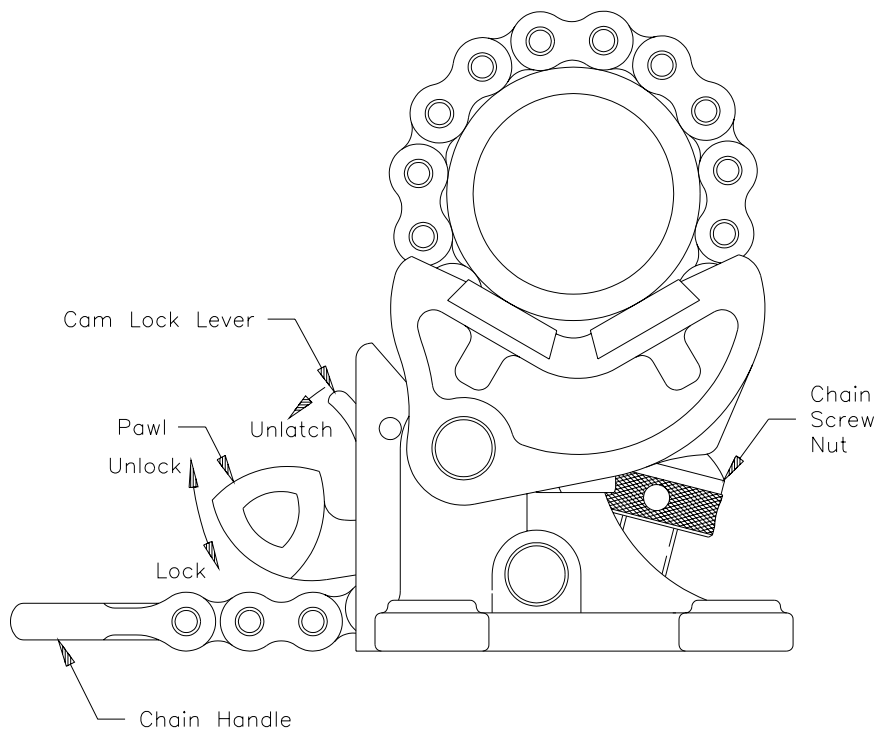

Vise Adjustment

Breaking Out

Load the tool and adjust the tong and vise as described above. Fully ratchet the tong. Turn the pressure control knob fully counter-clockwise, engaging the tong. When the tong stops, begin increasing the system pressure by turning the pressure control **slowly** clockwise. Keep increasing the system pressure until the connection is broken loose **or the working load of the tong is reached. Do not exceed the rating of the tong. Consult with GEARENCH as needed for help with the toughest break out jobs.** After the initial break out, ratchet the tong fully and then alternately engage / ratchet the tong until the connection is fully loosened.

Making Up

Load the tool and adjust the tong and vise as described above. Make up the connection hand tight using TITAN chain tongs. While pressing the **TONG RATCHET** button with the cylinder fully extended, adjust the pressure control knob until the desired make up torque is displayed. Engage the tong. If the cylinder fully retracts without stalling, cycle the tong (ratchet / engage). Continue until the cylinder stalls.

Calibration

Periodic calibration of the digital display and recorder outputs is recommended to maintain the highest possible accuracy. The following procedures should be used for calibration.

1. Connect a calibrated pressure indicator to any pressurized port on the console.
2. Remove the digital panel meter covers as shown. The power, signal and analog output wires must remain connected to the meter. See the calibration adjustment diagram below for the adjustment locations.
3. Apply pressure to the pressure indicator. The table below lists the recommended pressure values and the theoretical display and analog output values.
4. Adjust the zero and span controls as needed. Adjust the meter display prior to the analog output, as the meter controls will also affect the analog output.
5. Replace the digital panel meter covers and return the unit to service.

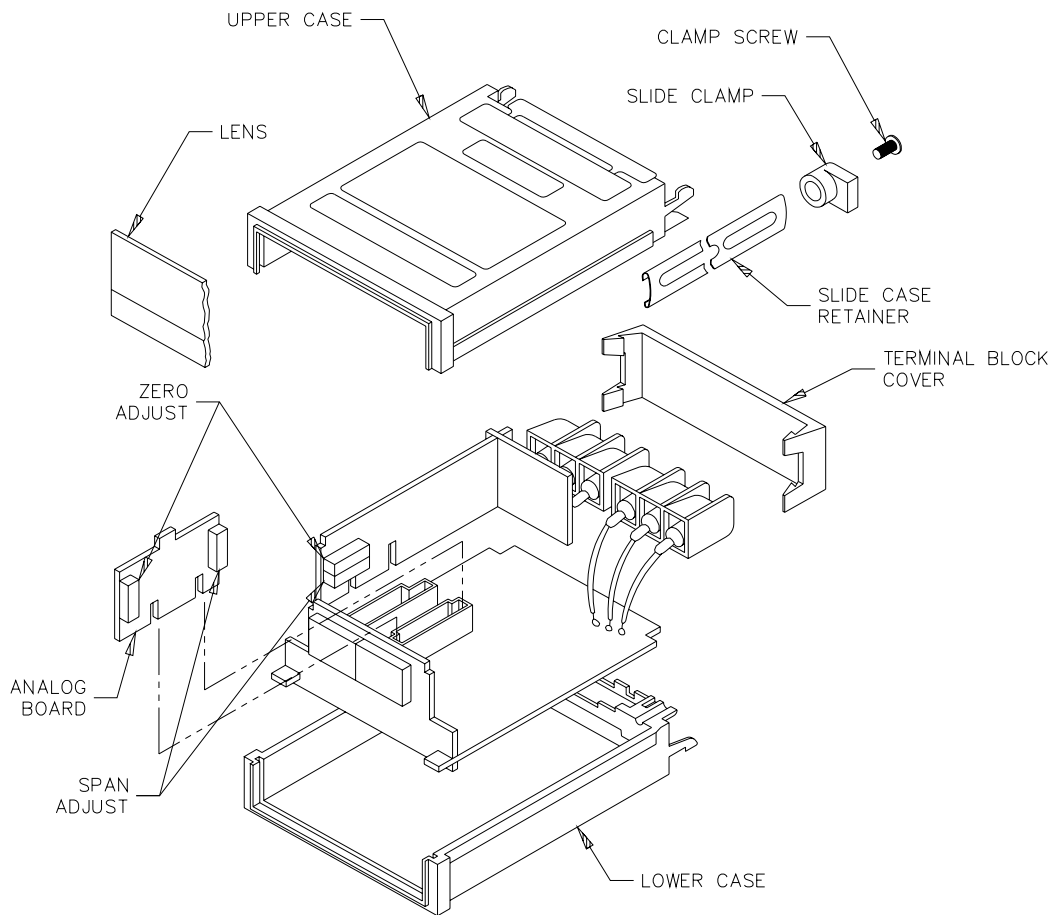

CALIBRATION ADJUSTMENTS

Recommended Calibration Setpoints

Pressure (psig)	Torque (ft-lbs)	Output (volts)
0	0	0.000
500	15,950	0.798
1000	31,910	1.596
1500	47,860	2.393
2000	63,810	3.191
2500	79,770	3.989
2800	89,340	4.467

Parts List

The following drawings, diagrams, and parts lists describe all parts, which may be needed as replacement items. Where appropriate, standard industrial, electrical, and hydraulic components have been used. Should a standard industrial item need replacing, the item may be purchased locally. To assist you in obtaining parts, the OEM component manufacturer and model numbers are shown on the parts list. Of course, all replacement parts will be supplied by GEARENCH if you prefer to order from us.

All tong, vise, and chain components are manufactured only by GEARENCH. DO NOT ATTEMPT TO SUBSTITUTE THESE COMPONENTS. The unit will not work properly unless these components are matched to the specific application. Consult our factory as your requirements change. Any non-GEARENCH substitutions of these components void all warranties and subject the user to assumption of liabilities resulting from subsequent use.

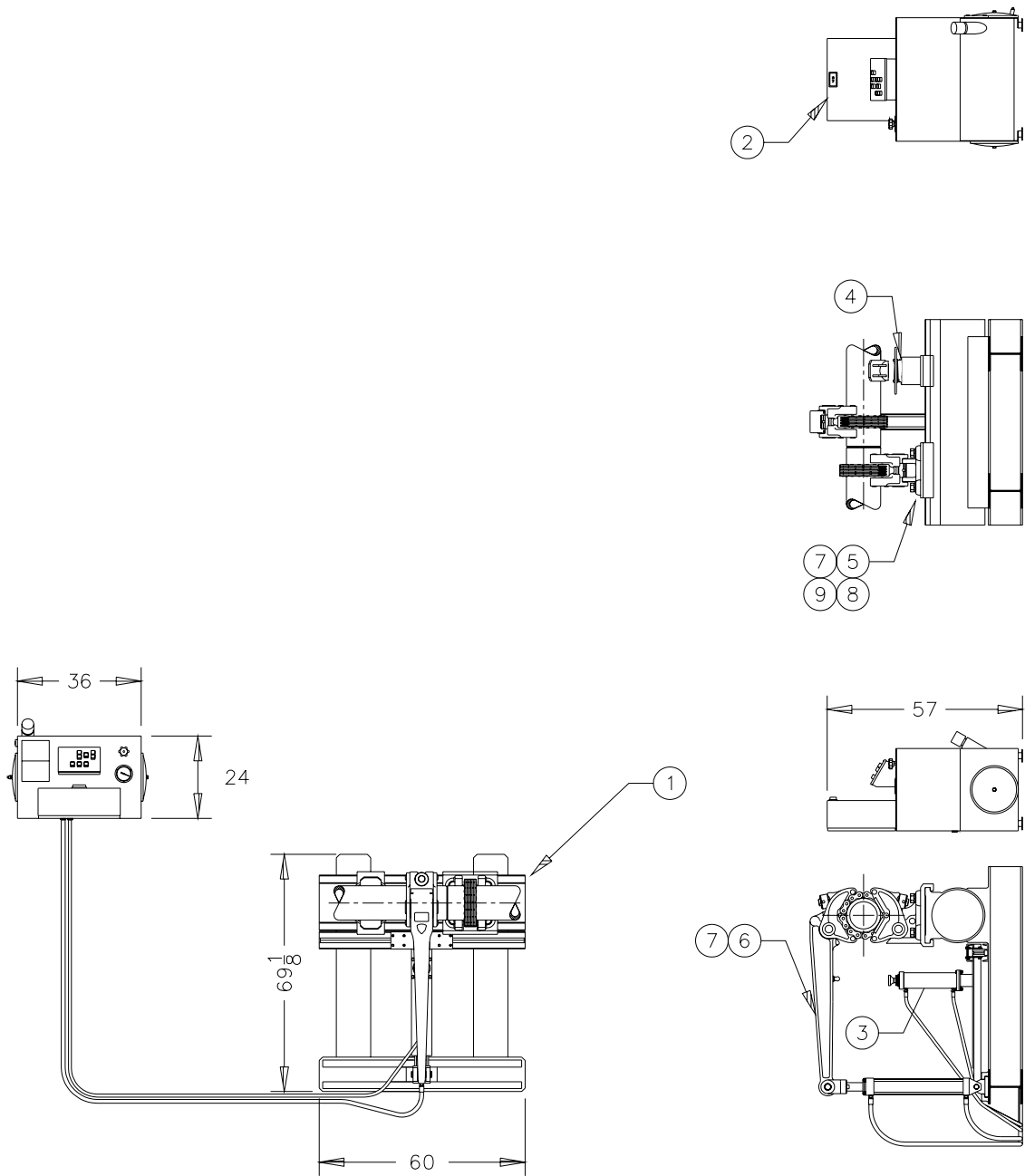

Final Assembly Parts List

Final Assembly Parts List

Item	Qty.	Part Number	Description	Notes
1	1	UHBASE-118-02	Base assembly	
2	1	UHCN-118-013	Console assembly	See pages 20-25
3	1	UCC-C	Cylinder carriage	See pages 26-27
4	1	UHVSA-118	Vee saddle assembly	See page 28
5	1	TVA118	Vise assembly	See page 29
6	1	UVTDA118	Tong assembly	See page 30
7	2	181-45-41T	Chain assembly	See page 31
8	1	UVS-114-1614-16	Vise slide	
9	4	HB09	Hex bolt	1-1/2-6UNC x 2-1/2 long

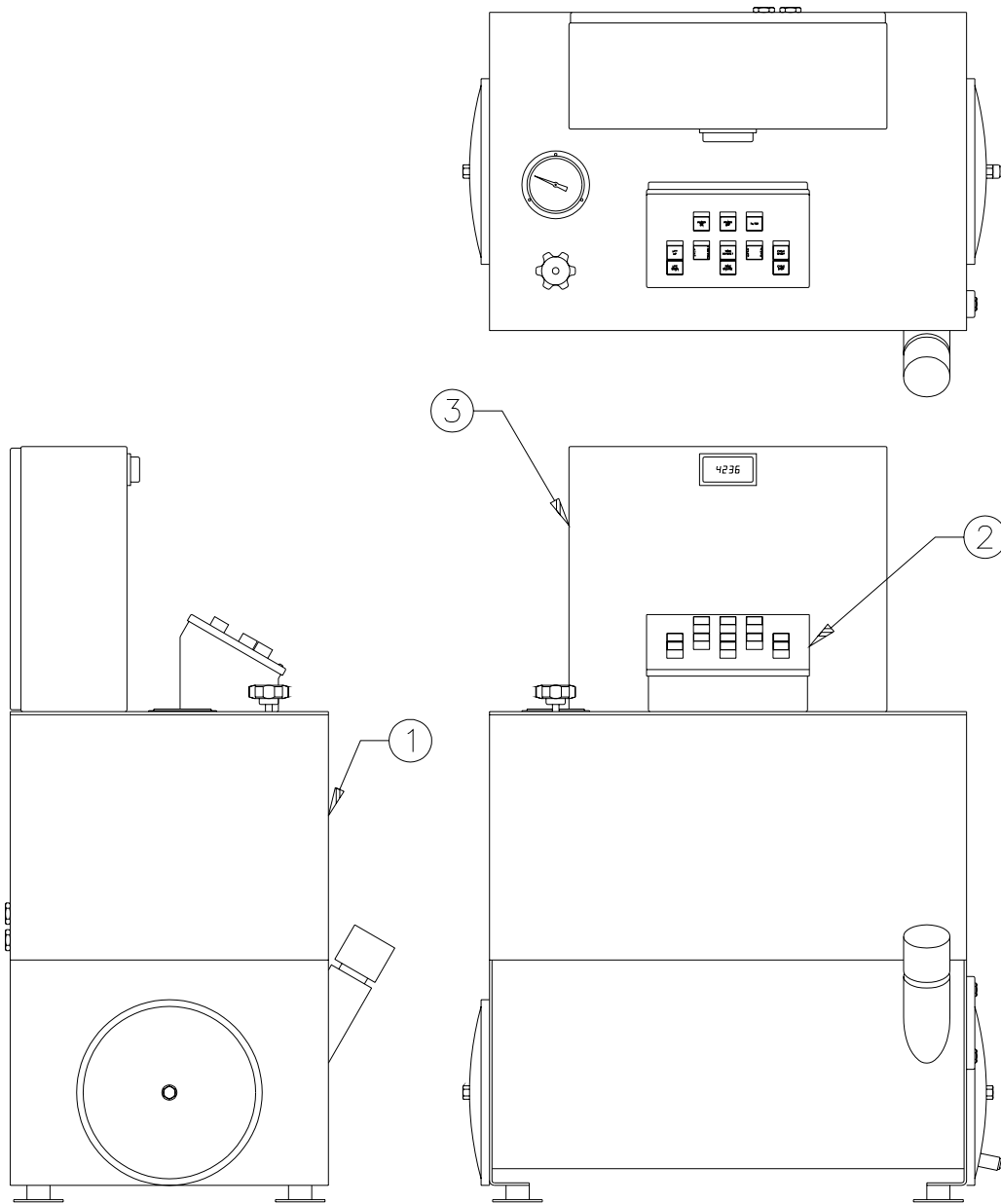

Console Assembly Parts List

Item	Qty.	Part Number	Description	Make / Model	Notes
1	1	UHCH-118-003	Hydraulic schematic		
2	1	UHCN-P1-23	Control panel		
3	1	UHCN-P2-023	Main electrical panel		
4	30 gal.	UHCH-OIL	Hydraulic oil	Chevron AW-ISO46	Or equal

LB = LIFT CYLINDER, BLIND END
 LR = LIFT CYLINDER, ROD END
 MB = MAIN CYLINDER, BLIND END
 MR = MAIN CYLINDER, ROD END

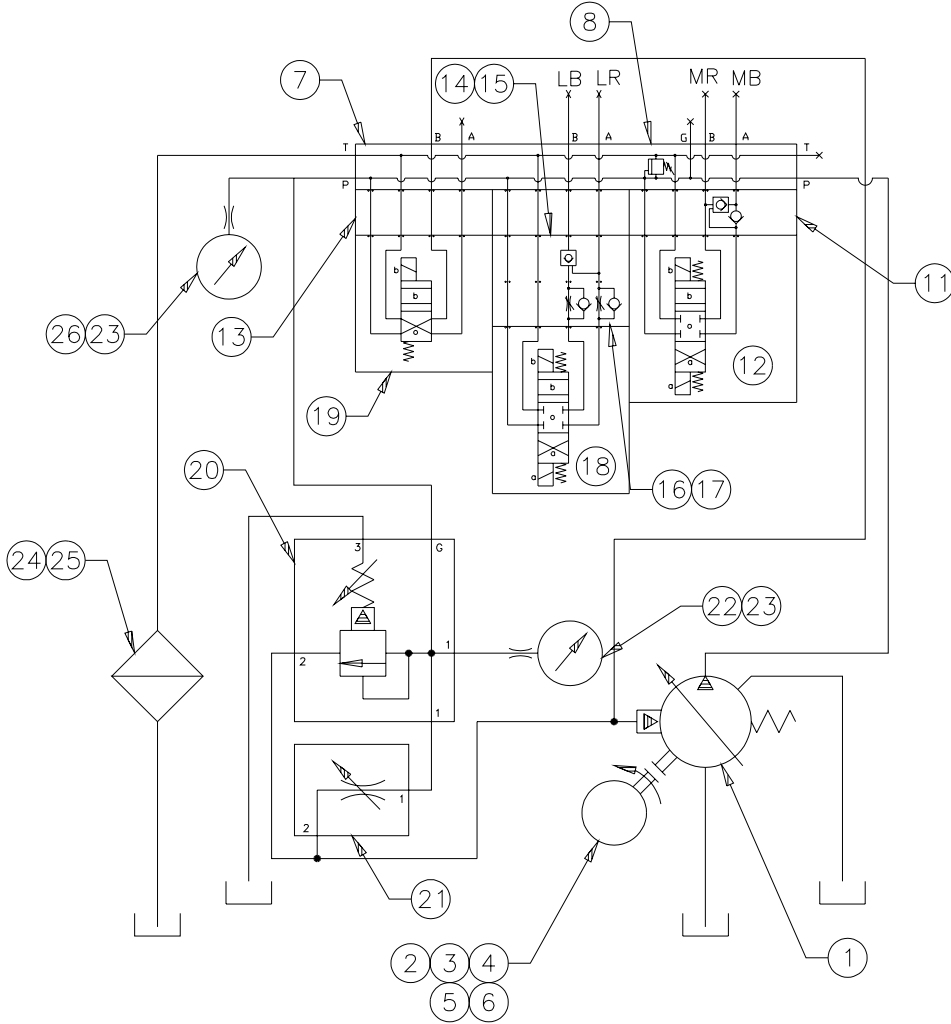

Hydraulic Schematic

Hydraulic Schematic Parts List

Item	Qty.	Part Number	Description	Make / Model	Notes
1	1	UHCH-P03	Pump	Oilgear PVW-20-LSAY-NNNN-885B	
2	1	UHCH-M11	Motor	Baldor CM3714T	Or equal
3	1	UHCH-M12	Motor coupling	Magnalloy M20011210	Or equal
4	1	UHCH-M13	Pump coupling	Magnalloy M20002808	Or equal
5	1	UHCH-M04	Coupling insert	Magnalloy M270N	Or equal
6	1	UHCH-M14	Adaptor	Magnalloy M182582B	Or equal
7	1	UHCH-V30	Manifold	Sun VPW	Or equal
8	1	UHCH-V08	Relief valve	Sun RPGC-LCN-3200psi	Or equal
11	1	UHCH-V21	Regenerative valve	Sun YDEV-XCN-BA	
12	1	UHCH-V22	Directional valve	Wandfluh AM4D101-R24	
13	2	UHCH-V07	Manifold reducer	Sun ZWU	Or equal
14	1	UHCH-V27	P.O. check body	Sun EBA	Or equal
15	1	UHCH-V17	P.O. check valve	Sun CKCB-XCN	Or equal
16	1	UHCH-V23	Flow control body	Sun GBY	Or equal
17	2	UHCH-V24	Flow control cartridge	Sun FDBA-LAN	Or equal
18	1	UHCH-V12	Directional valve	Wandfluh WDMFA06-ACB-R24	
19	1	UHCH-V11	Directional valve	Wandfluh WDMFA06-AC2-R24	
20	1	UHCH-V02	Pressure control	Sun RSDC-LAN-EHI	
21	1	UHCH-V03	Power limit valve	Sun NFCC-LDN-GAI	
22	1	UHCH-G01	Pressure gauge	Wika 213.40 4" FF-LBM 3000psi	Or equal
23	2	UHCH-G05	Gauge snubber	Cajon SS-4-SA-EW	Or equal
24	1	UHCH-B01	Filter element	Hycon 0085-MA-010-P	Or equal
25	1	UHCH-B02	Filter switch	Hycon VR2C	Or equal
26	1	UHCE-P1	Pressure transducer	Omega PX602-3KGV	Or equal

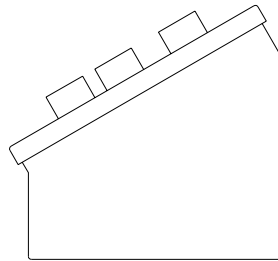
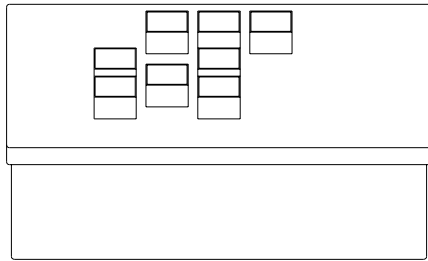
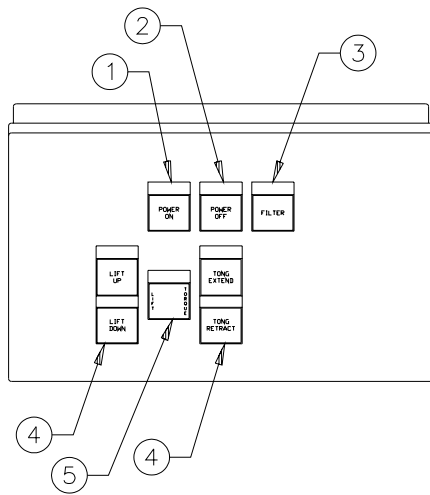

Control Panel Parts List

Item	Qty.	Part Number	Description	Make / Model	Notes
1	1	UHCE-S1	Push button switch	Allen-Bradley 800MB-CQA24GA	
2	2	UHCE-S2	Push button switch	Allen-Bradley 800MB-CB6D2	
3	1	UHCE-L1	Pilot light	Allen-Bradley 800MB-CQ24R	
4	4	UHCE-S3	Push button switch	Allen-Bradley 800MB-CA9B	
5	1	UHCE-S5	Selector switch	Allen-Bradley 800MB-HH2BLA	
6	2	UHCE-W23	3/4" x 45° liquid-tight conduit conn.	Thomas & Betts 5243	Or equal
7	2	UHCE-W25	3/4" conduit sealing ring	Thomas & Betts 5263	Or equal
8	1.50 ft	UHCE-W26	3/4" liquid-tight conduit		

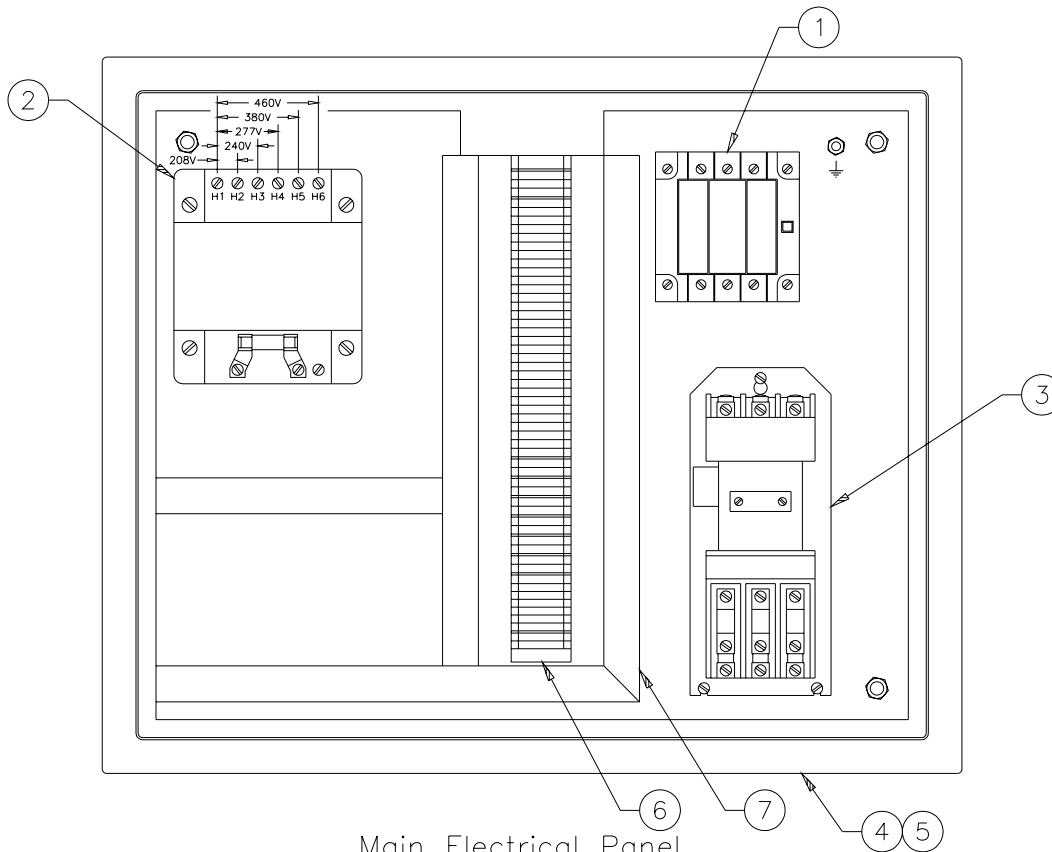

Main Electrical Panel
Parts List

Main Electrical Panel Parts List

Item	Qty.	Part Number	Description	Make / Model	Notes
1A	1	UHCE-S7	Disconnect switch	Allen-Bradley 194R-NJ030P34ER1	
1B	3	UHCE-F1	Fuse, 230V	Bussmann LPJ-30	Or equal
1B	3	UHCE-F4	Fuse, 460V	Bussmann LPJ-15	Or equal
1B	3	UHCE-F8	Fuse, 380V	Bussmann LPJ-17-1/2	Or equal
2A	1	UHCE-X3	Transformer	Acme TA-2-81324	
2B	1	UHCE-X2	Fuse kit	Acme PL-112601	
2C	1	UHCE-F7	Fuse	Bussmann FNM-10	Or equal

3A	1	UHCE-M1	Starter	Allen-Bradley 509-COJ	
3B	3	UHCE-H1	Heater, 230V	Allen-Bradley W64	
3B	3	UHCE-H2	Heater, 380/460V	Allen-Bradley W56	
4A	5	UHCE-W18	Cord connector	Hubbell SHC1011	Or equal
4B	5	UHCE-W24	3/8" sealing ring	Thomas & Betts 5261	Or equal
4C	5	UHCE-W27	3/8" lock nut	Thomas & Betts 140	Or equal
5A	2	UHCE-W23	3/4" x 45° liquid-tight conduit conn.	Thomas & Betts 5243	Or equal
5B	2	UHCE-W25	3/4" sealing ring	Thomas & Betts 5263	Or equal
5C	2.25 ft	UHCE-W26	3/4" liquid-tight conduit		
6A	38	UHCE-W08	Terminal block	Allen-Bradley 1492-W3	
6B	3	UHCE-W09	Jumper, 10 pole	Allen-Bradley 1492-CJ5-10	
6C	2	UHCE-W10	End anchor	Allen-Bradley 1492-EA35	
6D	1	UHCE-W11	End barrier	Allen-Bradley 1492-EB3	
6E	1	UHCE-W12	Mounting rail	Allen-Bradley 199-DR1	
6F	4	UHCE-W13	Partition plate	Allen-Bradley 1492-PP3	
7A	1	UHCE-W15	Wiring duct	Hoffman A-100100WH	Or equal
7B	1	UHCE-W16	Wiring duct cover	Hoffman A-100CWH	Or equal
8A	1	UHCE-I3	Digital panel meter	Newport Q9820S	
8B	1	UHCE-I2	Meter cover	Newport 6800-SPC4	
9	1	UHCE-W44	Dual binding post	Newark 35N847	Or equal

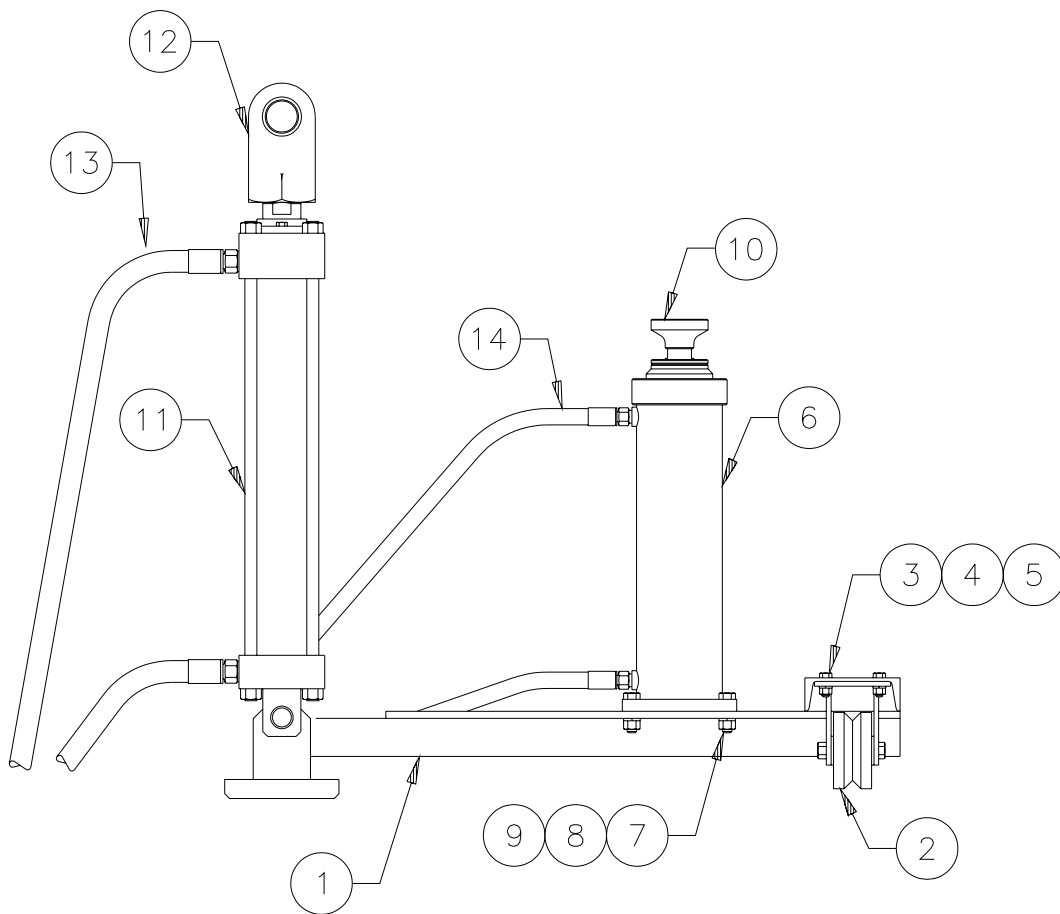

Cylinder Carriage Parts List

Item	Qty.	Part Number	Description	Make / Model	Notes
1	1	UCC-B-1	Carriage arm		
2	2	UCC-A-2	Caster	McMaster-Carr 2453T1	Or equal
3	8	HXS006	Hex bolt, 3/8-16UNC x 1		
4	8	HXW006	Lockwasher, 3/8"		
5	8	HXN044	Hex nut, 3/8-16UNC		
6	1	UCC-D-5	Lift cylinder	Westcraft 495250-1	
7	4	HXS007	Hex bolt, 1/2-13UNC x 1-3/4		
8	4	HXN043	Hex nut, 1/2-13UNC		
9	4	HXW005	Lockwasher, 1/2"		
10	1	UCC-D-4	Lift socket		

11	1	UHCY-118-C0	Main cylinder	Vickers/Aeroquip TZ10HP5N14W24000	
12	1	UHCY-118-RC	Cylinder rod clevis	Vickers/Aeroquip SH-662-10	
13	2	UHCH-H08	Hose assembly	Gates 12C2AT-12MP-12FJX-240	Or equal
14	2	UHCH-H09	Hose assembly	Gates 8C2AT-6MP-8FJX-240	Or equal
15	2	UHCY-118-HB	Handle bushing		
16	1	HP285	Handle pin		
17	2	HXRR175	Retaining ring	Waldes-Truarc 511-175	Or equal

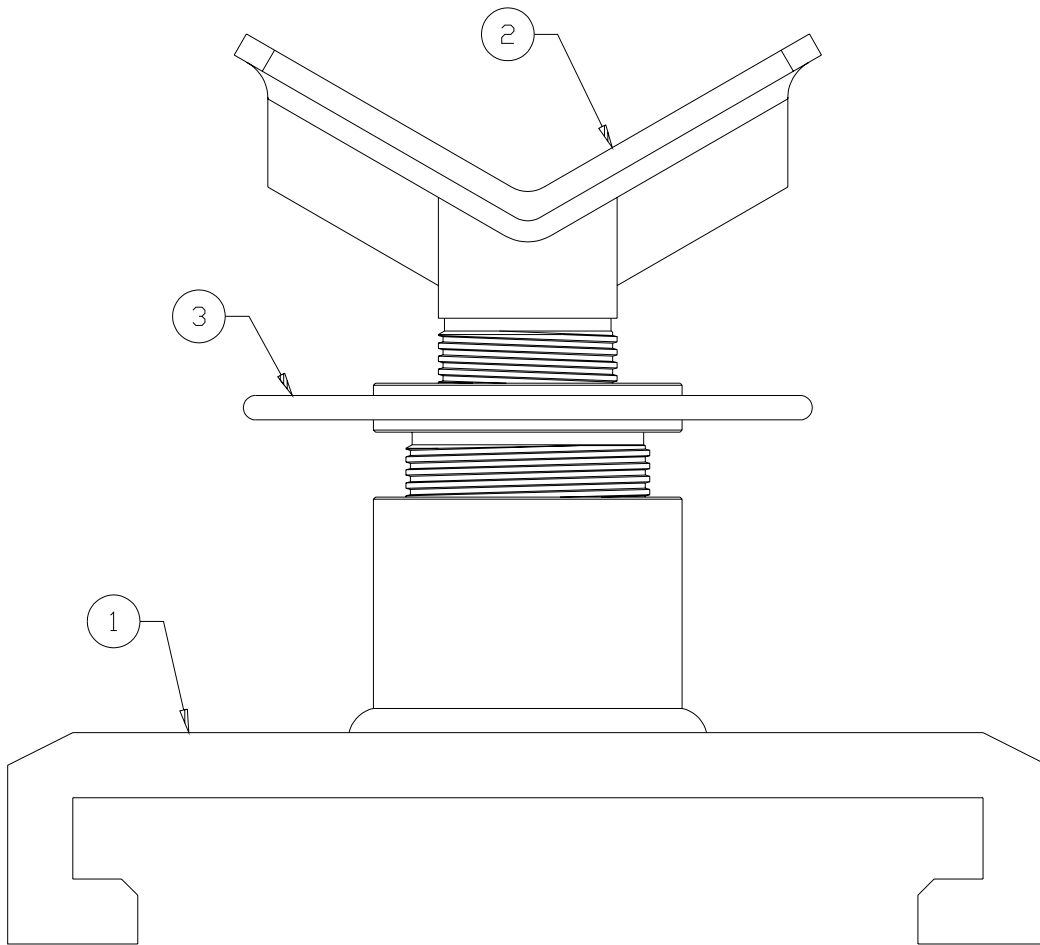

Vee Saddle Assembly Parts List

Item	Qty.	Part Number	Description	Make / Model	Notes
1	1	UHVSB-118	Vee saddle slide		
2	1	UHVSH-118	Vee saddle head		
3	1	UHVSN-118	Vee Saddle nut		

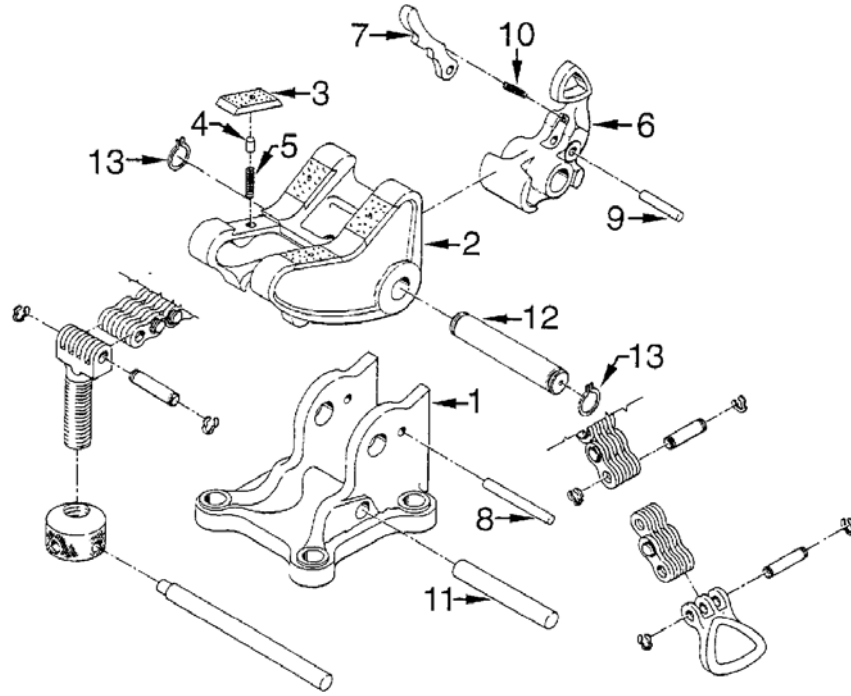

Vise Assembly Parts List

Item	Qty.	Part Number	Description
1	1	TVB118	Base
2	1	TVJ118	Jaw
3	4	HI10D	Diamond point insert
4	4	HP904	Insert key
5	4	HS21	Insert key spring
6	1	TVP118	Pawl
7	1	TVL118	Pawl latch
8	1	HP300	Pawl latch pin
9	1	HP327	Pawl latch rivet
10	1	HS01	Pawl latch spring
11	1	HP276	Base pin
12	1	HP294	Jaw pin w/ kliprings
13	2	HXRR225	Jaw pin klipring only

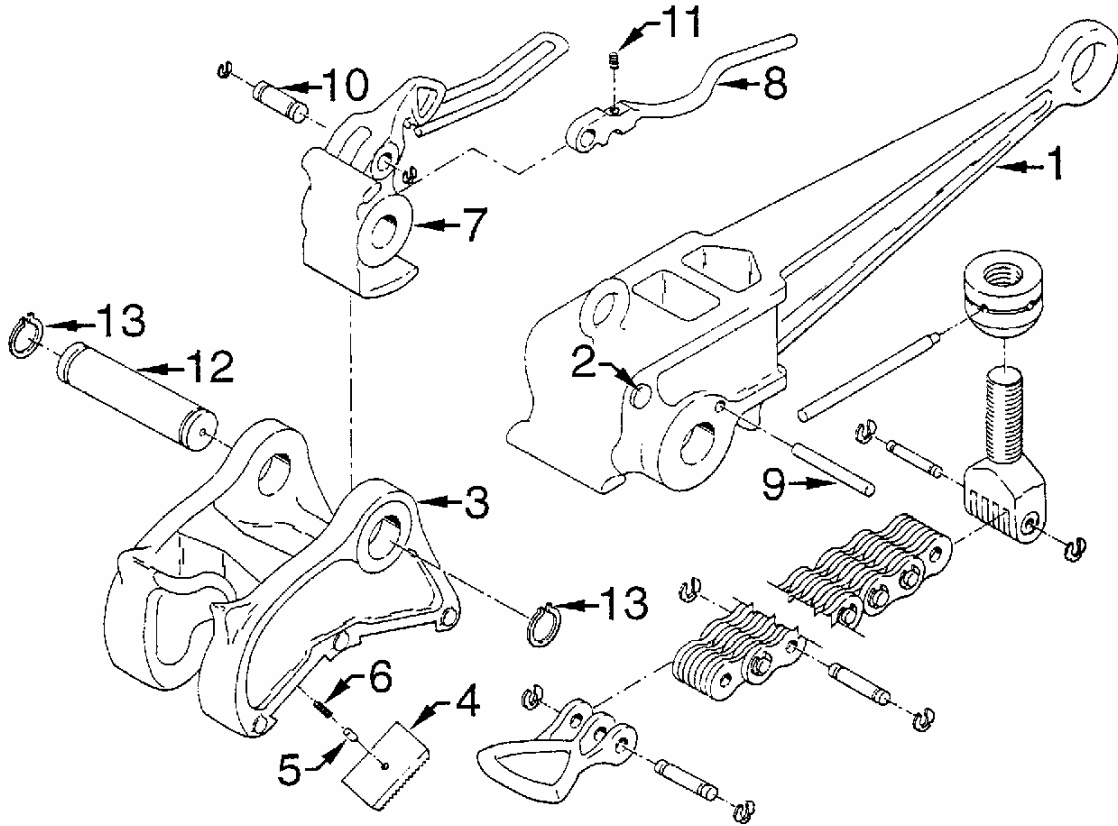

Tong Assembly Parts List

Item	Qty.	Part Number	Description
1	1	UVTDH118	Handle
2	1	HP276	Handle pin
3	1	TVJ118	Jaw
4A	2	HI10D	Diamond point insert
4B	2	HI10B	Blank insert
5	4	HP904	Insert key
6	4	HS21	Insert key spring
7	1	TVP118V	Pawl
8	1	TVL118V	Pawl latch
9	1	HP300	Pawl latch pin
10	1	HP327	Pawl latch rivet
11	1	HS01	Pawl latch spring
12	1	HP294	Jaw pin w/ kliplings
13	2	HXRR225	Jaw pin klipring only

Petol Special Chain Parts List

Item	Qty.	Part Number	Description
1	As req'd	181-45-02	Special chain only
2	As req'd	181-45-05	Special chain only
3	As req'd	181-45-07	Special chain only
4	1	HV05-45	Chain screw
5	1	HN03	Chain screw nut
6	1	HP327	Chain screw pin
7	1	HP954	Chain screw nut lever
8	1	HD4-45	Chain handle
9	1	HP327	Chain handle pin w/ cotter
10	As req'd	HP327	Chain pin w/ kliplings
11	As req'd	HXKR075	Klipring only

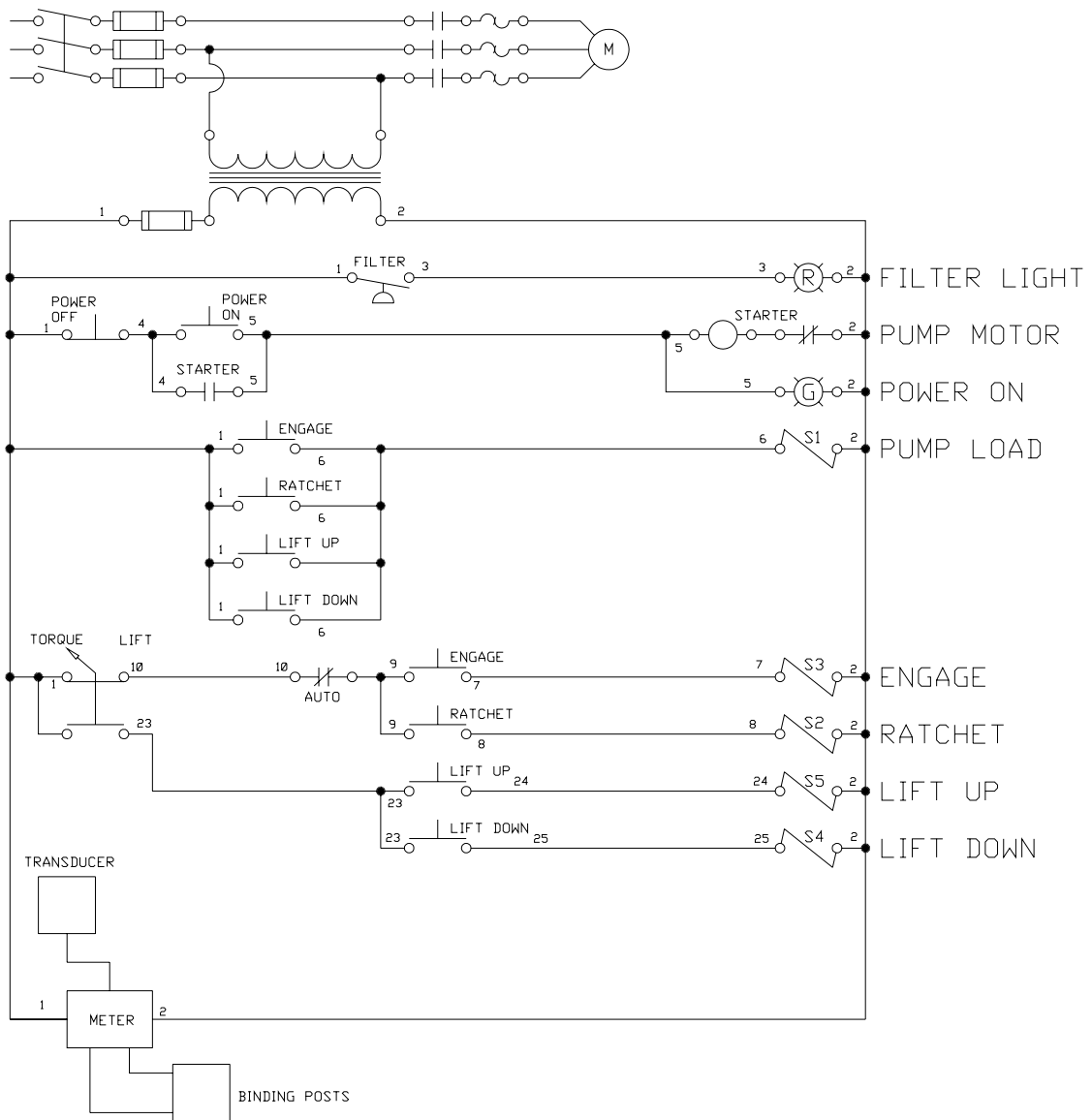

Electrical Schematic