

Petol Surgrip Casing Tong

SCT1020H

Data Book

**Gearench
P.O. Box 192
4450 South Highway 6
Clifton, Texas 76634
Phone: (254) 675-8651
Fax: (254) 675-6100**

© 2010 by GEARENCH. All rights reserved

Form SCT1020H revision 04/15/10

Table of Contents

Petol SCT1020H Surgrip Casing Tong Description	1
Warranty	2
Safe Practices and Procedures.....	4
Responsibility	4
Replacement Parts	4
Safety	4
Safe Practices	4
Safety Sources and Publications.....	5
Responsibility of Distributors.....	6
Tong Inspection.....	6
Overloading / Shock Loads / Side Loading.....	6
Safety Precautions	7
Operation	8
Suspension.....	8
Torque capacity	9
Use on couplings	9
Parts List.....	10
Wear Limits.....	11
Material Qualifications.....	12
Non-Destructive Evaluation.....	13
Weld Repairs	14
Certificates.....	16

Petol SCT1020H Surgrip Casing Tong Description

The SCT1020H Petol Surgrip Casing Tong was designed for making up and breaking out casing. It is rated for operation on 9-5/8" to 20" diameters.

The tong is adjusted by exchanging belts to work different nominal sizes of casing.

The SCT1020H offers the following features:

A high strength aramid fiber belt with polyurethane covering to grip the pipe and reduce the weight dramatically as compared to chain or lug jaws.

The tong is designed such that in case of an overload, the belt would fracture and extend. The tong will stay connected to the casing and no fragments would be expelled from the tong.

A secondary belt anchoring hole is located in the jaw to be used on couplings if required without the need for a different belt.

A hanger attached to the tong handle to suspend the tong during operation with multiple mounting holes to achieve a proper balance point.

Warranty

What Is Covered

Gearench tools are expressly warranted to you, the purchaser, to be free of defects in material and workmanship.

How Long Coverage Lasts

This express warranty lasts for the lifetime of the GEARENCH tool. Warranty coverage ends when the tool becomes unusable for reasons other than defects in workmanship or material.

How Can You Get Warranty Service

To obtain the benefit of this warranty, contact a GEARENCH sales representative in Clifton, Texas.
GEARENCH · 4450 South Highway 6 · P.O. Box 192 · Clifton, TX 76634

What Will We Do To Correct Problems

Warranted products will be repaired or replaced, at GEARENCH's option, and returned at no charge to you, the original purchaser; or, if after three attempts at repair or replacement during the warranty period, the product defect in material or workmanship persists, you can elect to receive a full refund of your original purchase price for the product.

What Is Not Covered

Defects, failures or conditions that are due to normal wear and tear, abuse or misuse, are not covered by this limited warranty. In addition, this limited warranty is in lieu of all other warranties, express or implied, verbal or written. To the maximum extent allowed by law GEARENCH disclaims all implied warranties, including implied warranties of merchantability and/or fitness for a particular purpose. GEARENCH also specifically denies any liability for any incidental damages and/or consequential damages, including but not limited to property damage to property other than the product itself, loss of sales profits, down time, costs or any other damages measurable in money, whether or not included in the foregoing enumeration.

Please be advised that some states do not allow the exclusion or limitation of incidental or consequential damages, so this limitation or exclusion may not apply to you. This warranty gives you specific rights, and you may also have other rights, which vary from state to state, province to province, or country to country.

Are Personal Injuries Covered

In the event you, someone working for you, or any other person sustain a personal injury as a result of using the GEARENCH tool, GEARENCH limits its potential liability for such a claim or injury to the fullest extent allowed by law, and disclaims and denies any liability for such personal injury.

Please be advised that some states do not allow the exclusion or limitation of liability for personal injuries, so the above limitation or exclusion may not apply to you, or the individual claiming injury.

No Other Express Warranty Applies

This GEARENCH LIMITED WARRANTY is the sole and exclusive warranty, express or implied for GEARENCH products. No employee, agent, dealer or other person is authorized to alter, modify, expand or reduce the terms of this warranty or to make any other warranty on behalf of GEARENCH.

Law Applicable

All matters related to the sale and/or use of the GEARENCH tool that is the subject of this limited warranty, along with the construction and enforcement of the terms of this limited warranty itself, shall be subject to the substantive and procedural laws of the state of Texas, not the conflicts of laws provisions of Texas, but rather the laws of Texas themselves.

Forum Selection Clause

Any dispute arising out of the sale and/or use of the GEARENCH tool that is the subject of this limited warranty shall be presented in the form of a claim or lawsuit to the offices of GEARENCH in Clifton, Bosque County, Texas. No claim or suit may be brought against GEARENCH, arising out of the sale and/or use of the tool, or arising out of the terms of this warranty, except in such forum. Purchase and/or use of the GEARENCH tool makes you subject to the benefits and limitations of this limited warranty. Accordingly, any writ, judgment or other enforcement, obtained from a jurisdiction, county, parish, state or federal court or other country, other than that from the forum identified above, shall be void and unenforceable against GEARENCH.

Arbitration Clause

In the event of dispute or claim arises out of the sale and/or use of the GEARENCH tool that is the subject of this limited warranty, or arises out of the interpretation or enforcement of the terms and conditions of this limited warranty, such dispute shall be submitted to binding arbitration pursuant to the rules of the American Arbitration Association. If required to accomplish the purpose of this Arbitration clause, the purchaser hereby expressly waives any right to demand trial by jury.

Complete Agreement

This express limited warranty contains the entire agreement regarding express or implied warranties related to the GEARENCH tool that is the subject of it. No writing or language contained in the purchase order or any other document of the purchaser, or invoice of GEARENCH or any intermediate seller, shall be construed as modifying, in any way, the rights and liabilities contained in this limited warranty. Gearench expressly disclaims any obligations expressed in any customer purchase order or document that are contrary to the terms and limitations of this warranty.

Severability

If any term or limitation contained in this limited warranty is deemed unenforceable by law, then the term shall be severed from the remaining portions of the limited warranty which shall remain enforceable.

All communications to GEARENCH regarding the use of the tool and any aspect of the sale of the tool of this limited warranty should be addressed to GEARENCH.

GEARENCH · 4450 South Highway 6 · P.O. Box 192 · Clifton, TX 76634

Safe Practices and Procedures

Responsibility

"It is the responsibility of the employer to train the employee in the proper selection and usage of tools, chains, etc., and to ensure that they are selected and used in that manner. In many instances, injury results because it is assumed that anybody knows how to use common hand tools. Observations and the record show that this is not the case. A part of every job instruction program should therefore be detailed training in the proper use of hand tools (and of all other special tools and equipment needed to accomplish the job)." - (Source: National Safety Council)

"Employers are responsible for the safe condition of tools and equipment used by employees, including tools and equipment which may be furnished by employees." - (Source: OSHA 1910.242A)

Replacement Parts

Use only PETOL replacement parts - no other parts are of comparable strength, quality and interchangeability.

Safety

While we pride ourselves on the quality and dependability we build into GEARENCH tools and products, we caution users that it is only prudent to know and follow the simple rules of safety when using our products, or anyone else's.

Always follow safe practices and procedures in accordance with the recommendations of OSHA, The National Safety Council (NSC), The Hand Tools Institute (HTI), The National Association of Chain Manufacturers (NACM), The International Association of Drilling Contractors (IADC), Etc. All applicable Governmental rules, regulations or restrictions, now in effect or which may be promulgated, take precedence over the suggestions in this publication. The information in this publication is designed to supplement standard safe practices and procedures, not in lieu of, or replacement thereof.

Safe Practices

(Source: The National Safety Council)

Failure to observe one or more of the following five safe practices accounts for most hand and powered tool accidents:

1. ALWAYS WEAR SAFETY GOGGLES TO PROTECT EYES
2. SELECT THE RIGHT TOOL FOR THE JOB
3. KEEP TOOLS IN GOOD CONDITION
4. USE TOOLS CORRECTLY
5. KEEP TOOLS IN A SAFE PLACE

Safety Goggles must always be worn by persons in any area where hand and powered tools are being used.

Never apply excess leverage to a wrench or tool by means of a "Cheater Bar". Never strike wrenches and tools with hammers or other objects.

All tools should be kept clean, inspected on a regular basis, and replaced when they show signs of wear.

Be especially careful not to place yourself in a position that could result in bodily injury in the event of a failure. Brace yourself firmly and pull rather than push when wrenching. (If necessary to push, do so with the flat of the hand rather than gripping around the wrench.)

Never stand under or near loads being hoisted off the ground.

READ SAFE PRACTICES AND PROCEDURES MANUAL, CATALOG INFORMATION AND PRODUCT LABELING PRIOR TO OPERATION.

Spinning and drill pipe chain, cathead chain, and the PETOL Connecting Link attachment are designed for the specific purpose for which the name indicates. Chains and attachments that are to be used for any other purpose should be selected in accordance with the recommendations of ASTM, NACM, Rigger's Handbook, and the commercial chain manufacturer's technical manuals.

Safety Sources and Publications

In the interest of Safety the following sources of Safety information is furnished:

The Hand Tools Institute (HTI)
25 North Broadway
Tarrytown, New York 10591
(914) 332-0040
www.hti.org

The National Safety Council (NSC)
1121 Spring Lake Drive
Itasca, Illinois 60143-3201
(630) 285-1121
www.nsc.org

International Safety Council
1121 Spring Lake Drive
Itasca, Illinois 60143-3201
(630) 285-1121

Responsibility of Distributors

IT IS THE RESPONSIBILITY OF THE PURCHASERS OF GEARENCH PRODUCTS TO CONVEY THE INFORMATION IN THIS PUBLICATION AND ANY OTHER INFORMATION RELATING TO THE INDIVIDUAL PRODUCT, THROUGH THE CHANNELS OF DISTRIBUTION, DOWN TO AND INCLUDING THE INDIVIDUAL USING THE PRODUCT

NOTE:

In view of the fact that the actual use determines whether safety requirements have been met, the ultimate responsibility to comply rests with the end user.

Tong Inspection

It is recommended that the tong be visually inspected on a daily basis for signs of damaged components. The belt should be visually inspected on a daily basis for indications of exposed cords or fractured cords. The hanger bolts should be tightened on a daily basis.

It is recommended that the tong handle and jaw be removed and magnetic particle inspected on an annual basis for indications of cracking. Please refer to the appropriate section for inspection criteria and allowable repair procedures.

Overloading / Shock Loads / Side Loading

Damage to the tong is possible if the following conditions are present. Users are cautioned to be aware that these practices could result in premature breaking of the tong.

Attempting to “inch” loads which are beyond the rated capacity of the tool.

Striking the tool with a hammer or other object while force is being exerted in an attempt to loosen a "frozen" joint.

Side pull on the belt. Side pull can be caused by pulling or pushing on the tong in a direction that is not along a perpendicular plane, unlevelled mounting of the vise, inadequate support of the part being broken out, and improper seating of the part being broken out in the tong or vise. Improper seating will occur when the OD of the part is not consistent within the width of the tong or vise jaw.

Safety Precautions

1. Always wear safety goggles to protect eyes.
2. Select the right tool for the job.
3. Keep tools in good condition.
4. Use tools correctly.
5. Keep tools in a safe place.
6. Wear protective clothing, gloves and safety shoes as appropriate.
7. Use only PETOL & TITAN replacement parts to ensure proper strength.

Operation

The typical application of one Surgrip Casing Tong is shown in the figure below. Normally an additional tong is used as a backup. The backup tong is not shown for clarity. The tong will exert torque in the direction shown. The tong will ratchet when moved in a direction opposite to the line pull. Ratcheting is used when the tong must be pulled more than once to completely makeup or breakout the connection.

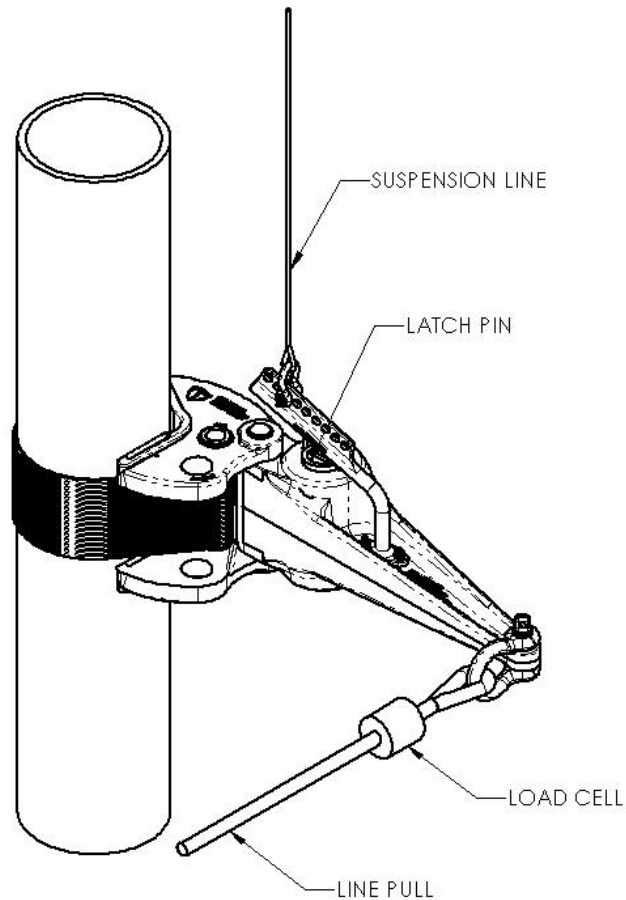

Suspension

The tong should be suspended by the attached hanger. Use the appropriate hole in the hanger to obtain the best possible balance of the tong. Always use a suspension line of adequate capacity to safely hold up the tong during operation.

Torque capacity

The Surgrip Casing Tong utilizes a different belt for each nominal diameter. The maximum working loads are shown in the table below.

Diameter	Belt Part Number	Torque Arm Length (inches)	Maximum Torque (foot-pounds)	Maximum Line Pull (pounds)
9 5/8	SCTB1020H-0958	43.81	70,000	19,200
9 7/8	SCTB1020H-0978	43.94	70,600	19,300
10	SCTB1020H-1000	44.00	70,900	19,300
10 3/4	SCTB1020H-1034	44.38	72,800	19,700
11 3/4	SCTB1020H-1134	44.88	75,300	20,100
11 7/8	SCTB1020H-1178	44.94	75,700	20,200
12 1/4	SCTB1020H-1214	45.13	76,600	20,400
13 3/8	SCTB1020H-1338	45.69	79,400	20,900
13 5/8	SCTB1020H-1358	45.81	80,100	21,000
14	SCTB1020H-1400	46.00	81,000	21,100
16	SCTB1020H-1600	47.00	86,000	22,000
16 3/4	SCTB1020H-1634	47.38	87,900	22,300
18	SCTB1020H-1800	48.00	91,100	22,800
18 3/8	SCTB1020H-1838	48.19	92,000	22,900
18 5/8	SCTB1020H-1858	48.31	92,600	23,000
20	SCTB1020H-2000	49.00	96,100	23,500

WARNING: Under no circumstances should the maximum working load be exceeded. Always use a load cell or other calibrated indicating device to monitor the line pull on the tong to avoid an overload.

Use on couplings

The jaw has two belt anchoring holes. One hole is marked “PIPE”, when this hole is fixed to the handle, the tong will latch on the pipe for the appropriate belt. The third hole is marked “COUPLING”, this hole will allow the tong to be latched onto a coupling with a diameter of one inch over the pipe diameter.

Parts List

The following drawings, diagrams, and parts lists describe all parts, which may be needed as replacement items.

All tong components are manufactured only by GEARENCH. DO NOT ATTEMPT TO SUBSTITUTE THESE COMPONENTS. The tong will not work properly unless these components are matched to the specific application. Consult our factory as your requirements change. Any non-GEARENCH substitutions of these components void all warranties and subject the user to assumption of liabilities resulting from subsequent use.

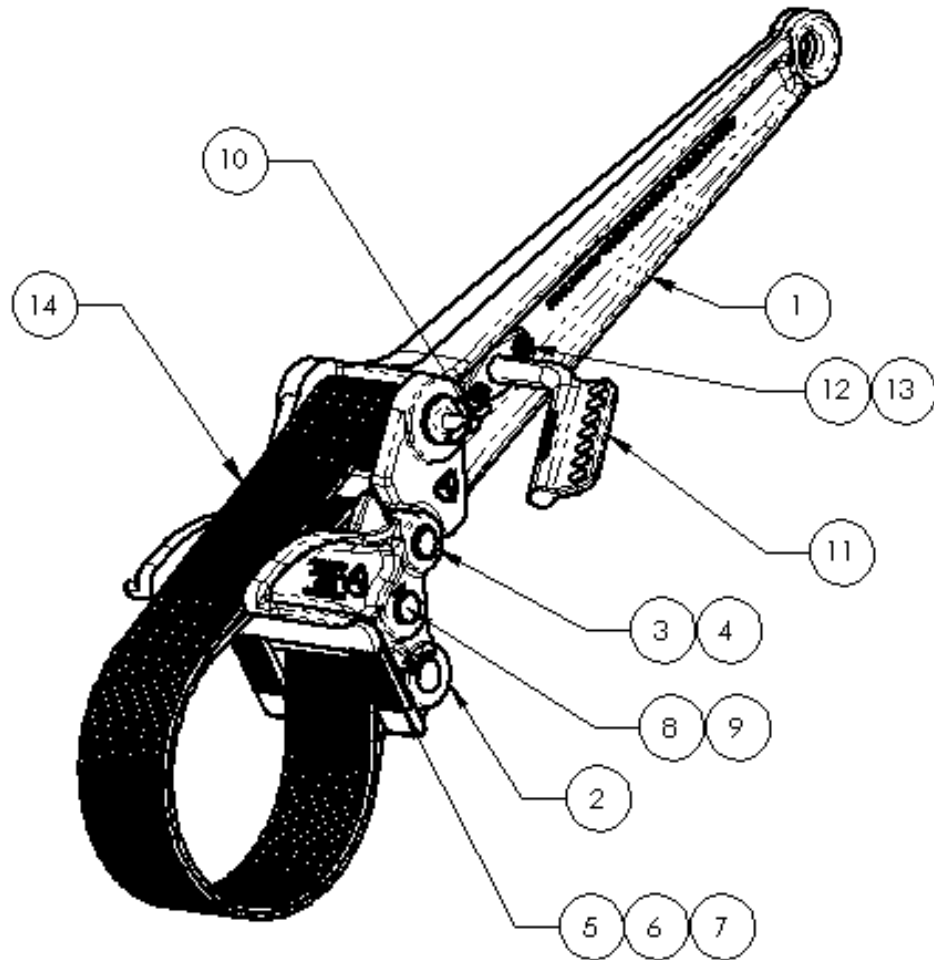

Parts List

Item	Qty.	Part Number	Description	Notes
1	1	SCTH1020H	Handle	
2	1	SCTJ1020H	Jaw	
3	1	HP397	Jaw-handle pin	
4	2	HXSR200	Retaining ring	Smalley WSM-200 (or equal)
5	2	HI10D	Diamond point insert	
6	2	HP904	Insert key	
7	2	HS21	Insert key spring	
8	1	HP398	Belt – jaw pin	
9	2	HXSR275	Spiral retaining ring	Smalley WSM-275 (or equal)
10	1	HP399	Latch pin	
11	1	HH19	Hanger	
12	2	HXS047	Hex bolt	½-20UNF x 2 gr. 5
13	2	HXN062	Slotted nut	½-20UNF
13a	2	HXC008	Cotter pin	1/8 x 1-1/4
14	1	See table	Belt	As required (see page 9)
15	1	HXL001	Lanyard	Not shown

Wear Limits

The following table indicates limiting diameters on the components of the Surgrip Casing Tong. When localized wear is beyond any one of the limits indicated, the component should be replaced.

Part Number	Description	Location	Limit diameter
HP397	Jaw – handle pin	Pin body	1.970 (min)
HP399	Belt latch pin	Pin body	3.595 (min)
HP398	Master pin	Pin body	2.720 (min)
SCTH1020H	Handle	Jaw pin hole	2.035 (max)
SCTH1020H	Handle	Latch pin hole	3.660 (max)
SCTH1020H	Handle	Load loop	1.750 (max)
SCTJ1020H	Jaw	Handle pin hole	2.035 (max)
SCTJ1020H	Jaw	Master pin holes (2 places)	2.785 (max)

Material Qualifications

The following table is a list of the materials and grades used in the manufacture of the SCT1020 Surgrip Casing Tong.

Part Number	Description	Material	Hardness	Yield Strength (min)	Tensile Strength (min)
SCTH1020H	Handle	ASTM A148	38-42 Rc	150 ksi	160 ksi
SCTJ1020H	Jaw	ASTM A148	38-42 Rc	150 ksi	160 ksi
HP397	Pin	AISI 4140	38-42 Rc	165 ksi	180 ksi
HI10D	Insert	AISI M2	58-62 Rc	N/A	N/A
HP398	Pin	AISI 4140	38-42 Rc	165 ksi	180 ksi
HP399	Pin	AISI 4140	38-42 Rc	165 ksi	180 ksi
HH19	Hanger	ASTM A536 Gr. 65-45-12	N/A	45 ksi	65 ksi
SCTB1020H	Belt	Aramid- Polyurethane Composite	N/A	N/A	N/A

Non-Destructive Evaluation

The figure below indicates the critical areas of the tong handle. A critical area is defined as an area in which no unrepaired crack indications are permitted and in which no major weld repairs are permitted. There are no critical areas on the jaw that meet these criteria.

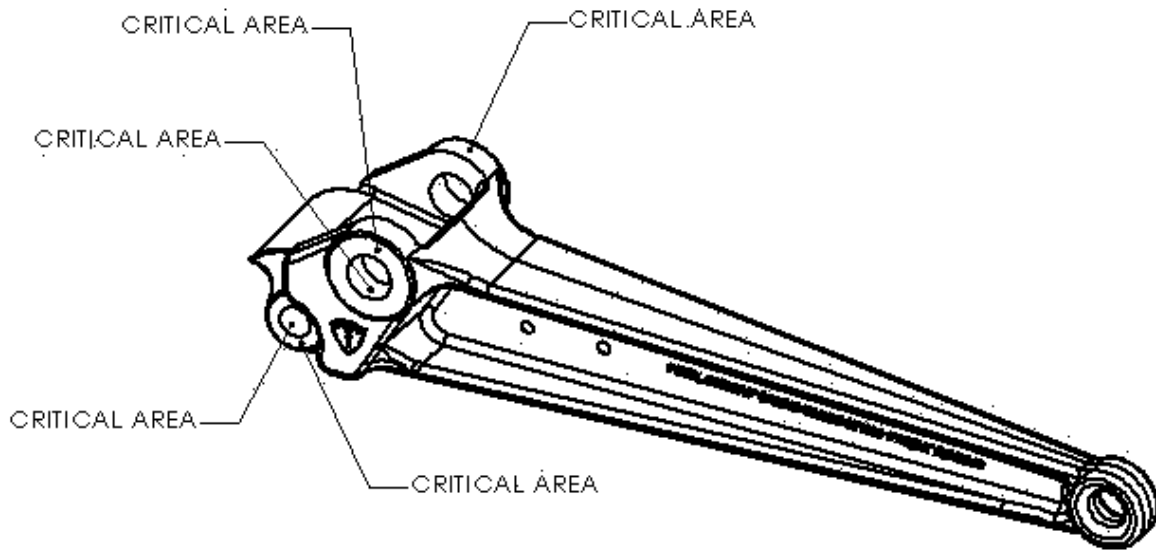

Weld Repairs

Scope:

This procedure is to be followed for minor repairs of crack indications in heat treated alloy steels. A weld repair shall be considered minor when the depth of the cavity does not exceed 30% of the actual wall thickness or 1 inch, whichever is smaller, or when the extent of the cavity does not exceed approximately 10 square inches. Major weld repairs must be performed by Gearench or an approved repair center using appropriate procedures followed by full heat treatment and load testing.

Application:

This procedure applies to steel castings, forgings and, wrought with carbon content between 0.25% and 0.31%.

Weld preparation:

The crack indication is to be removed by carbon arc gouging, grinding, or machining until all indication is removed. Magnetic particle inspection shall be used to verify that the crack indication has been removed.

Filler material and process:

Repairs shall be made with the FCAW process with a filler material of class E71T-1 or equivalent with CO₂ shielding gas by a qualified welder.

Preheat:

Preheat the weld area to 400°F minimum.

Interpass temperature:

The interpass temperature to be 850°F maximum. All weld slag to be removed prior to application of additional layers.

Post weld heat treatment:

Post heat immediately after welding to 400 - 800°F for 4 minutes minimum at temperature. Wrap in insulating blanket and allow to slow cool to ambient temperature.

Weld blending and inspection:

The weld is to be ground flush with the adjacent parent material. The weld is to be inspected by magnetic particle to verify that the weld area is free of all crack indications.

Certificates